UMB Protocol 1.0
Universal Measurement Bus
Communication Protocol
for Meteorological Sensors

IRS31-UMB
VS20-UMB
R2S-UMB
WS400-UMB
WS600-UMB
ANACON-UMB
IRS21CON-UMB
LCOM



Status 14.12.2007
Protocol Version 1.0
Document Version 1.5

G. LUFFT MESS- UND
REGELTECHNIK GMBH

POSTFACH 4252
70719 FELLBACH
TEL. 49 (711) - 51822-0
FAX 49 (711) - 51822-41



Table of Contents

1	Version History	4
2	Preliminary Remarks	6
2.1	Restricted Guarantee	6
2.2	Nomenclature.....	6
2.3	Data Format and Byte Order in the Communication Protocol:.....	6
2.4	Physical Connection and Hardware Structure	6
2.5	Software Protocol.....	6
2.6	Products.....	6
3	UMB Binary Protocol (Version 1.0)	7
3.1	Protocol Stack (Framing)	7
3.1.1	Application Layer	7
3.1.2	Presentation Layer/Session Layer/Transport Layer	7
3.1.3	Network Layer.....	7
3.1.4	Data Link Layer.....	7
3.1.5	Physical Layer	8
3.1.6	Timing Sensor.....	8
3.1.7	Timing Master	8
3.1.8	Summary	9
3.2	Topology	10
3.3	Addressing with Class and Device ID	11
3.3.1	Examples for the Creation of Addresses	11
3.4	CRC Checksum	11
3.5	Commands (Datagrams).....	12
3.5.1	Summary of Commands	12
3.5.2	Hardware and Software Version (20h)	13
3.5.3	Device Information (2Dh).....	13
3.5.4	Read Out EEPROM (21h)	14
3.5.5	Programme EEPROM (22h).....	14
3.5.6	Programme EEPROM with PIN (F0h)	14
3.5.7	Online Data Request (23h).....	15
3.5.8	Multi-Channel Online Data Request (2Fh).....	15
3.5.9	Offline Data Request (24h).....	16
3.5.10	Reset / Default (25h).....	16
3.5.11	Reset with Delay (2Eh).....	16
3.5.12	Status Request (26h).....	16
3.5.13	Last Error Message (2Ch)	16
3.5.14	Set Time / Date (27h)	17
3.5.15	Readout Time / Date (28h)	17
3.5.16	Test / Calibration Command (29h).....	17
3.5.17	Monitor (2Ah).....	17
3.5.18	Protocol Change (2Bh).....	18
3.5.19	Set New Device ID (30h)	18
3.6	Status and Error Codes	19
3.7	Data Types.....	21
3.8	Measurement Value Types	21

3.9	Channel Assignment.....	22
3.9.1	Channel Assignment – General Allocation	22
3.9.2	Channel Assignment Device Class 1 Road Sensor.....	23
3.9.3	Channel Assignment Device Class 2 Rain Sensor	24
3.9.4	Channel Assignment Device Class 3 Visibility Sensor	25
3.9.5	Channel Assignment Device Class 4 Temperature/Humidity	26
3.9.6	Channel Assignment Device Class 5 Wind Sensor	26
3.9.7	Channel Assignment Device Class 6 Universal Measurement Transmitter.....	27
3.9.8	Channel Assignment Device Class 7 Compact Weather Station	28
3.9.9	TLS Channel Assignment.....	29
3.10	Units List.....	29
3.10.1	Temperature	29
3.10.2	Humidity	29
3.10.3	Lengths	29
3.10.4	Velocities	29
3.10.5	Electrical Variables	30
3.10.6	Frequency.....	30
3.10.7	Pressure	30
3.10.8	Volumes.....	30
3.10.9	Time.....	30
3.10.10	Miscellaneous	30
3.11	Example of a Binary Protocol Request.....	31
3.12	Comments about Broadcast.....	32
4	UMB ASCII Protocol.....	33
4.1	Construction.....	33
4.1.1	Summary of the ASCII Commands.....	33
4.1.2	Online Data Request (M)	33
4.1.3	Protocol Change (X)	34
4.1.4	Reset / Default (R).....	34
4.1.5	Reset with Delay (D).....	34
4.1.6	Device Information (I)	34
4.2	Error Codes in the ASCII Protocol	35
5	Appendix.....	36
5.1	CRC Calculation	36
5.1.1	Example of a CRC-CCITT Calculation in C	36
5.2	Automatic Readout of a Network	38
5.2.1	Background.....	38
5.2.2	Necessary ID Configuration of the Sensors.....	38
5.2.3	Scanning the Network.....	38
5.3	Data Types in UMB Products per TLS2002 FG3.....	39
5.3.1	Example of a TLS Measurement Value Request.....	39
5.3.2	Supported TLS-DE Types FG3.....	40
5.3.3	DE Type 70 “Road Surface Condition” (RSC)	43
5.3.4	DE Type 71 “Precipitation Type” (PT).....	44
5.3.5	DE Type 140 “Door Contact” (DC).....	45
5.3.6	DE Type 140 Inverted “Door Contact” (DC).....	45
5.4	Character Table for Text Editions	46

1 Version History

Document Version	Date	Compiled by	Description of Amendment
0.0	24.11.2004	SR	Compilation
0.1	14.06.2005	EES	First edition
0.2	22.12.2005	EES	Update 2 wire interface hardware
0.3	07.02.2006	EES	Renaming to UMB, supplement "Automatic Readout of a Network" and device information
0.4	07.03.2006	EES	Nomenclature amended, BC command summary amended
0.5	09.03.2006	EES	- Device information command extended by addition of E2 variable and details of the type of information in the answer - Channel assignment extended by relative measurement values
0.6	04.04.2006	EES	List of units amended
1.0	12.04.2006	EES	- Measurement value types amended - Device information command extended by addition of measurement value type First approved version
1.1	19.05.2006	EES	- Status byte inserted in the answer of Readout Time/Date (28h) command
		SR	- Status 29h undervoltage defined
		EES	- Channel assignment per device class amended - Amendments to TLS coding in the channel assignment and the list of supported DE types per FG3 in the appendix - Logo included
1.2	18.07.2006	EES	- Status 2Ah hardware fault defined - Status 2Bh fault in the measurement defined - List of units amended (l/m ²) - ASCII character set amended - Measurement value type 'Sum' 14h defined
		BEL	- RRS integrated
		EES	- Status 52h Channel Overrange defined - Status 53h Channel Underrange defined - List of units amended (hPa hectopascals)
		BEL	- Types of precipitation defined in accordance with the WMO on RRS channel 700
		EES	- General channel assignment 10500 defined for pulses and 2000 for further TLS channels - Measurement value type 15h defined for 'vectorial mean value' - TLS channels for ANACON amended (LD and 2 nd channel) - Status codes for calibration amended - Change in the answer to the TLS channel request (adaptation to existing implementation)
1.3	08.08.2006	EES	- Response time of the calibration command (29h) changed from short to long - Status code 36h changed to 'Channel deactivated' - Data type of the TLS channels adapted in the general channel assignment of the device classes - Channel assignment Chapter moved back to later in document - Response time for online data request (23h) changed to 'long' due to computing-intensive channels (e.g. ANACON) - Instructions for 'Multi-Channel Online Data Request' (2Fh) amended in relation to long response times - ANACON TLS channel DE type 66 TPT dewpoint amended - Various channel assignments amended - Command 29h renamed 'test command' as this is used not only for adjustment but also to test various device functions

1.4	12.09.2006	EES	- Comment expanded to state that no TLS channels are available in the ASCII protocol
		SR	- Road sensor channel assignment - Mil length unit added
1.5	14.12.2007	EES	- 'Set new id' command vers. 1.1 amended - Info added to status code 28h - Knots unit added
		BEL	- Non-metric units inch and mil / inch/h and mil/h added on R2S channels (chapters 3.9.3, 3.10.3 and 3.10.9)
		EES	- Channel list added for ANACON-UMB (abs. humidity and pressure) - Device class and channel list added for compact weather station - Product list amended - Channel assignment device class 6 universal measurement transmitter for precipitation and pulses amended
		EES	- Product designations for the compact weather station amended - Error code INIT_ERROR (2Ch) = Error on device initialization and OS_ERROR (2Dh) = Error in operating system added - Channel designations for absolute and relative air pressure amended

2 Preliminary Remarks

The protocols described here were developed for meteorological sensors and facilitate simplified communication with various devices such as IRS31-UMB, VS20-UMB and R2S-UMB.

2.1 Restricted Guarantee

The methods and settings described in this document allow the device to be configured using standard PC software. The selection of incorrect settings can lead to the loss of the specified measurement accuracy and device failure. Lufft reserves the right to restrict the guarantee to the products in the case of the application of the procedures described here.

2.2 Nomenclature

Device: The term “device” is used in this document as a synonym for the equipment family of meteorological sensors such as IRS31, VS20 and R2S.

Hexadecimal values are identified by the suffix ‘h’.

Decimal values are identified by the suffix ‘d’.

‘BC’ identifies commands which can be transmitted by broadcast. ‘NBC’ stands for ‘not broadcastable’ (please also see Comments about Broadcast on page 32).

2.3 Data Format and Byte Order in the Communication Protocol:

LONG: LowLowByte LowHighByte HighLowByte HighHighByte

INT: LowByte HighByte

FLOAT: Per IEEE format (4 bytes)

2.4 Physical Connection and Hardware Structure

In a network, the device is controlled via a half-duplex RS485 2 wire interface. The ISOCON also has an RS232 interface. The factory-set baud rate is 19200 baud with 8 data bits, one stop bit and no parity (8N1).

2.5 Software Protocol

Configuration and polling of the device takes place in binary protocol. As the system operates without collision detection, the master-slave principle is strictly observed. In order to simplify communication, especially for polling measurement values, it is possible to switch over to ASCII protocol (**although not all products currently support this feature**). In doing so, it should be noted that it is not possible to configure the device in ASCII protocol and the measurement values are not CRC-safe. In addition, TLS channels are not available here.

2.6 Products

This description is applicable to the following products

Product	Part No.:	Description
VS20-UMB	8366.U50	Visibility sensor
R2S-UMB	8367.U01 8367.U02	Radar rain sensor for precipitation
IRS31-UMB	8510.Uxxx	Intelligent road sensor
WSx-UMB		Compact weather stations
ANACON-UMB	8160.UANA	UMB analog transmitter
IRS21CON-UMB	8410.UISO	UMB interface converter for IRS21
LCOM		

3 UMB Binary Protocol (Version 1.0)

The OSI (Open Systems Interconnection) reference model of the International Standards Organisation (ISO) can be used to abstract the logical steps of the header construction.

The datagrams pass through the individual layers of the protocol stack and in doing so are progressively provided with the header data. In this way a frame is created, the maximum length of which is limited to 255 bytes. 210 bytes are available for reference data.

Little endian is applicable to the transmission of word variables (Intel, lowbyte first).

3.1 Protocol Stack (Framing)

3.1.1 Application Layer

A command consists of a minimum of two characters: The command <cmd> and the version number of the command <verc>. The optional payload can contain up to 210 characters. The value range of one byte of the payload is 0 to 255.

1	2	3 - 4	5 - 6	7	8	9	10	11 ... (8 + len) optional	9 + len	10 + len 11 + len	12 + len
						<cmd>	<verc>	<payload>			

3.1.2 Presentation Layer/Session Layer/Transport Layer

The services of layers 4 (transport layer), 5 (session layer – communications control layer) and 6 (presentation layer) are not required and therefore transparent.

3.1.3 Network Layer

Addressing takes place via a 16 bit address. The formulation of these addresses is described on page 11.

In the network layer, the receiver (<to>) and sender (<from>) addresses are added to a datagram received from the upper layer. The version number <ver> denotes the structure of the header and is the binary protocol version number (Version 1.0). The upper nibble represents the version number and the lower nibble the amendment number.

Example: Version 1.0 → <ver> = 10h = 16d

1	2	3 - 4	5 - 6	7	8	9	10	11 ... (8 + len) optional	9 + len	10 + len 11 + len	12 + len
	<ver>	<to>	<from>			<cmd>	<verc>	<payload>			

3.1.4 Data Link Layer

4 control characters are used to identify the data framework:

SOH (01h), STX (02h), ETX (03h), EOT (04h).

SOH (Start Of Header) marks the start of the datagram and header. The control character is followed by the header version number. This defines the format of the datagram and leaves space for later enlargement.

1	2	3 - 4	5 - 6	7	8	9	10	11 ... (8 + len) optional	9 + len	10 + len 11 + len	12 + len
SOH	<ver>	<to>	<from>	<len>	STX	<cmd>	<verc>	<payload>	ETX	<cs>	EOT

3.1.5 Physical Layer

2 wire RS485, standard baud rate 19200 baud, 8 data bits, 1 stop bit and no parity.

3.1.6 Timing Sensor

The following criteria have been defined for the implementation of the protocol in the sensor:

- The receive interrupt can be blocked for critical measurements.
- After receiving a command, a sensor (slave) must begin to transmit the answer after time t_a at the latest, however not sooner than the minimum pause of 3 characters. If the measurement takes longer during the online request, the last recorded measurement value is transmitted and measurement takes place after the request.
- The answer times (t_a) are divided into 2 categories:
 - o Standard: The answer time t_a is 50 ms maximum;
 - o Long: A longer processing time is necessary for certain commands. In this case the maximum response time is 500 ms. Such commands are identified accordingly.
- The device does not respond if a command exceeds the permitted response time; however, it cannot be assumed from this that the command was not processed, as it may transpire that, for example, the time expires whilst a command is being executed.

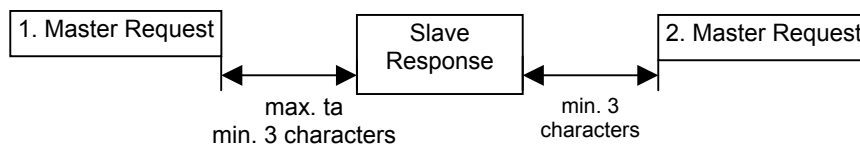

3.1.7 Timing Master

- A strict **master-slave principle** must be maintained. There must be only one master per system.
- The master must observe a minimum pause of 3 characters following receipt of a slave message.
- After a broadcast has been transmitted, the next command may only take place at the earliest after 500 ms.
- A retry may be necessary in the case of special sensors. The recommended number of retries is 3. The interval of the messages must be at least 500 ms, however not longer than 3 s in total.

3.1.7.1 Timeout Time Master

After this time has lapsed, the master can assume that the message has been lost and start the retries.

The timeout times with a direct RS232 connection are as follows:

- Commands with standard response time: 60 ms
- Commands with long answer time: 510 ms

ATTENTION:

If the request takes place via Ethernet or GPRS, for example, the timeout time must be adjusted in accordance with the runtime of the medium used. There should be an option to set the timeout times in the configuration of the master software for this purpose.

3.1.8 Summary

The complete frame is illustrated here in summary:

1	2	3 - 4	5 - 6	7	8	9	10	11 ... (8 + len) optional	9 + len	10 + len 11 + len	12 + len
SOH	<ver>	<to>	<from>	<len>	STX	<cmd>	<verc>	<payload>	ETX	<cs>	EOT

SOH	Control character for the start of a frame (01h) 1 byte
<ver>	Header version number, e.g.: V 1.0 → <ver> = 10h = 16d; 1 byte
<to>	Receiver address, 2 bytes
<from>	Sender address, 2 bytes
<len>	Number of data bytes between STX and ETX; 1 byte
STX	Control character for the start of the reference data transmission (02h); 1 byte
<cmd>	Command; 1 byte
<verc>	Version number of the command; 1 byte
<payload>	Data bytes; 0 – 210 bytes
ETX	Control character for the end of the reference data transmission (03h); 1 byte
<cs>	Checksum, 16 bit CRC; 2 bytes
EOT	Control character for the end of the frame (04h); 1 byte

Control characters: SOH (01h), STX (02h), ETX (03h), EOT (04h).

3.2 Topology

A sensor network is constructed as follows:

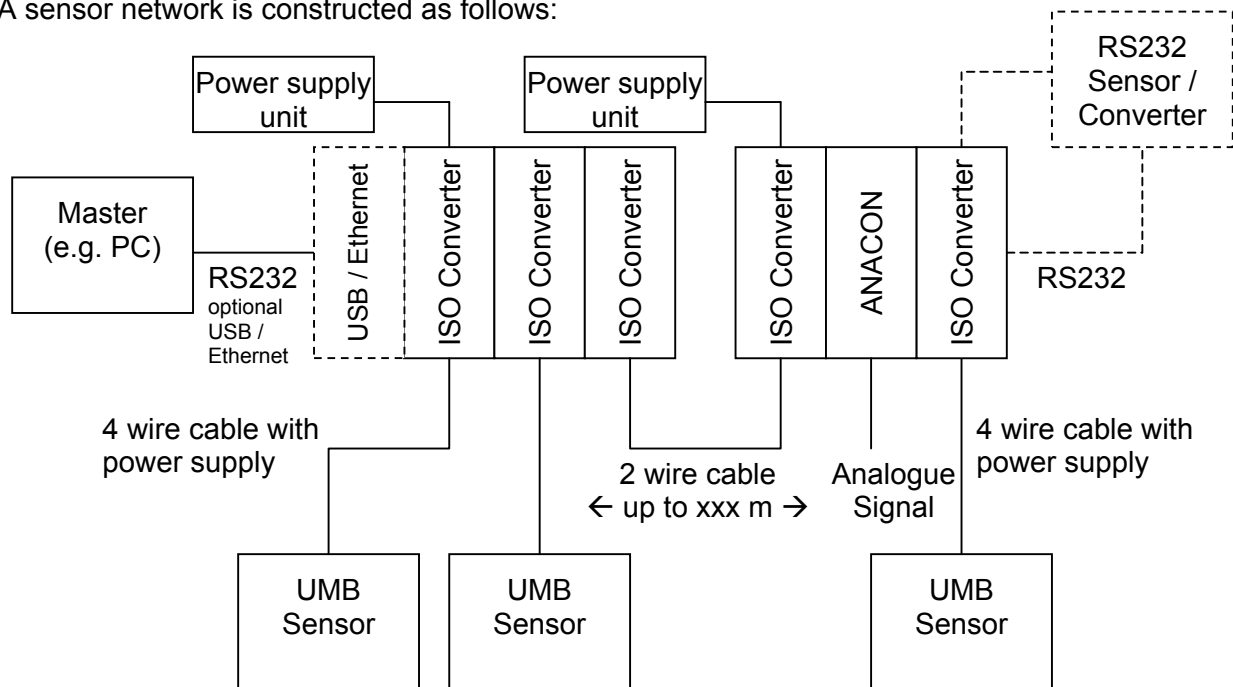

Master: The master is connected to the RS232 interface built into the ISO converter. An interface module for USB and Ethernet via virtual COM port is also available as an option.

Sensor: The sensors are connected via a 4 wire connection and one ISO converter in each case; the converter also provides the power supply for the sensor.

ISO Converter: The converters are connected together by means of plug-in connectors which can be arranged in sequence. In order to create larger distances between ISO converters, they may be connected together using a crossed connection.

Sensors from other Manufacturers

Provided that sensors from other manufacturers also operate in accordance with the master-slave principle, they may be connected to the RS232 interface of an ISO converter; it is also conceivable that sensors with RS422/485/2 wire/4 wire could be connected to the measurement network via a suitable converter (e.g. Phoenix).

Measurement Modules

Intelligent measurement modules, which make the analogue signals available on the bus, can also be provided for sensors without a data interface (e.g. 0 – 1V or 4 – 20mA).



3.3 Addressing with Class and Device ID

Addressing takes place by means of a 16 bit address. This is divided into a sensor class ID and a device ID.

Address (2 bytes = 16 bits)			
Bits 15 – 12 (upper 4 bits)		Bits 11 – 0 (lower 12 bits)	
Class ID (0 to 15)		Device ID (0 – 4095)	
0	Broadcast	0	Broadcast
1	Road sensor	1 - 4095	available
2	Rain sensor		
3	Visibility sensor		
4	Temperature/Humidity		
5	Wind sensor		
6	Universal measurement transmitter (e.g. ANACON)		
7	Compact weather station		
8			
9			
10			
11 - 14	Reserved for additions		
15	Master / control devices		

ID = 0 is designated as broadcast for both classes and devices. This makes it possible to send a broadcast on a specific class. However, this only makes reasonable sense if there is only one device of this class on the bus.

3.3.1 Examples for the Creation of Addresses

If, for example, a road sensor is to be addressed with the device ID (serial number) 0423, this is achieved as follows:

Class ID for the road sensor is 1 = 1h

Device ID (serial number) is 0423 = 1A7h

Placing the class and device ID's together gives the following address 11A7h = 4519d.

Further examples:

Class ID	Device ID	Address	Explanation
1h	1A7h (0423d)	11A7h (4519d)	Road sensor with device ID 0423
0h	000h (0000d)	0000h (0d)	Broadcast to all devices and sensors
1h	000h (0000d)	1000h (4096d)	Broadcast to all road sensors
3h	4D2h (1234d)	34D2h (16522d)	Visibility sensor with device ID 1234

3.4 CRC Checksum

The CRC-CCITT checksum is formulated with the following polynomial:

$$x^{16} + x^{12} + x^5 + 1 \text{ (LSB first mode; start value FFFFh)}$$

The checksum is formulated via all bytes prior to the checksum (1 ... 9 + len), i.e. from SOH to ETX inclusive.

The little endian byte sequence is applicable to the checksum.

If a device receives a frame with an incorrect CRC, there is no reaction to this command.

Programme examples of a CRC calculation can be found in the Appendix.

3.5 Commands (Datagrams)

For reasons of clarity, the following presentation of commands is limited to the application layer. The following short-form is used for the purpose of better presentation:

<cmd>_{<verc>}[<payload1>ⁿ, <payload2>ⁿ, ...]

Hexadecimal values are identified by the suffix 'h'. Character strings are in double quotation marks and concluded by the null character (00h). The little endian byte sequence (Intel, lowbyte first) applies to the transmission of words. Wildcards for syntactic units are identified by angle brackets. If the length of the variable is greater than 1 byte, this is designated 'n' in the index.

3.5.1 Summary of Commands

Sorted by <cmd>:

<cmd>	Description	BC	RT	IRS21 CON	VS20	R2S	ANA CON	WSx	IRS3 1
20h	Hardware and software version		s	●	●	●	●	●	●
21h	Read out EEPROM		l	●	●	●	●	●	●
22h	Programme EEPROM		l		●	●	●	●	●
23h	Online data request		l	●	●	●	●	●	●
24h	Offline data request		s						
25h	Reset / default	●	s	●	●	●	●	●	●
26h	Status request		s	●	●	●	●	●	●
27h	Set time / date	●	s						
28h	Read out time / date		s						
29h	Calibration command		l	●	●	●	●	●	
2Ah	Monitor		l	●	●	●	●	●	●
2Bh	Protocol change	●	s	●	●	●	●	●	●
2Ch	Last fault message		s	●	●	●	●	●	●
2Dh	Device information		s	●	●	●	●	●	●
2Eh	Reset with delay	●	s	●	●	●	●	●	●
2Fh	Multi-channel online data request		l	●	●	●	●	●	●
30h	Set new device ID	●	s		●	●	●	●	●
							●	●	
40h – 7Fh	Reserved for device-specific commands (see device description)								
80h – 8Fh	Reserved for development			●	●		●	●	●
				●	●		●	●	●
F0h	Programme EEPROM with PIN		l		●		●	●	●
					●		●	●	●

RT = response time; s = short; l = long

BC = broadcastable command

ATTENTION: A device (sensor) only accepts a command if it was sent **by a master** (observance of master-slave principle).

3.5.2 Hardware and Software Version (20h)

Command <cmd>: 20h (NBC)

Command version <verc>: 1.0

Data <payload>: none

Description: This command serves to request the hardware and software version of the addressed device.

Call: 20h_{10h}[]

Answer: 20h_{10h}[00h, <hardware>, <software>]

Example: SW-Version 2.3 →<software> = 17h = 23d
 HW-Version 6 →<hardware> = 06h = 6d

3.5.3 Device Information (2Dh)

Command <cmd>: 2Dh (NBC)

Command version <verc>: 1.0

Data <payload>: <info>, <option>ⁿ

Description: This command returns the following device information:

Call: 2Dh_{10h}[<info>, <option>ⁿ]

<info> Type of information desired

<option>ⁿ Option for further information required

<info>	<option>	Description	<answer>
10h	none	Device identification	<ID> ⁴⁰ e.g. 'Visibility Sensor VS20'
11h	none	Device description	<desc> ⁴⁰ e.g. 'Visibility A92 West'
12h	none	Hardware and software version	<hardware>, <software> Version 2.3 = 17h = 23d
13h	none	Expanded version info	<SerNo> ² , <MMYY> ² , <Project> ² , <PartsList>, <PartsPlan>, <hardware>, <software>, <e2version>, <DeviceVersion> ²
14h	none	EEPROM size	<e2_size> ²
15h	none	No. of channels available	<channels> ² , <blocks>
16h	<block>	Numbers of the channels	<block>, <channels>, [<channel> ²] ^{<channels>}
20h	<channel> ²	Meas. variable of channel	<channel> ² , <variable> ²⁰ e.g. 'visibility'
21h	<channel> ²	Meas. range of channel	<channel> ² , <min> ⁿ , <max> ⁿ Values as channel
22h	<channel> ²	Meas. unit of channel	<channel> ² , <unit> ¹⁵ e.g. 'm'
23h	<channel> ²	Data type of channel	<channel> ² , <data_type> e.g. 16h for float
24h	<channel> ²	Meas. value type	<channel> ² , <mv_type> e.g. 13h for mean value
30h	<channel> ²	Complete channel info	<channel> ² , <variable> ²⁰ , <unit> ¹⁵ , <mv_type>, <data_type>, <min> ⁿ , <max> ⁿ

Answer: 2Dh_{10h}[00h, <info>, <answer>]

Comment: On a request for the numbers of the channels (16h), up to 100 are consolidated in one block (beginning with block 0). If a sensor has more than 100 channels, there are correspondingly more blocks. The number of blocks is indicated in the request for the number of available channels (15h).

On a request for the data type of a channel (23h) or the complete channel information (30h), the length n of min and max depends on the data type. (See 3.7 Data Types)

3.5.4 Read Out EEPROM (21h)

Command <cmd>: 21h (NBC)

Command version <verc>: 1.0

Data <payload>: <start>², <length>

Description: With this command, the transmission of <length> bytes from the storage location <start> is initiated from the EEPROM.

Call: 21h_{10h}[<start>², <length>]

Answer: 21h_{10h}[00h, <start>², <length>, <data>^{<length>}]

Response time: long

Comment: The maximum number of bytes (<length>) is 200.

3.5.5 Programme EEPROM (22h)

Command <cmd>: 22h (NBC)

Command version <verc>: 1.0

Data <payload>: <start>², <length>, <data>^{<length>}

Description: With this command, a data block <data> of length <length> bytes is transmitted to the receiver. This is written to the EEPROM with effect from the address <start>. When all bytes are programmed, the sender of the command is informed about the success of the action by means of an acknowledgement.

Call: 22h_{10h}[<start>², <length>, <data>^{<length>}]

Answer: 22h_{10h}[00h]

Response time: long

Comment: As the device's maximum time to answer is limited to 50ms, the maximum number of bytes (<length>) depends on the device because it can take varied lengths of time until the EEPROM is programmed. If a number of bytes is specified which the device is unable to process, the maximum number is specified in the error code.

There are write-protected storage locations in the EEPROM which cannot be written on.

3.5.6 Programme EEPROM with PIN (F0h)

Command <cmd>: F0h (NBC)

Command version <verc>: 1.0

Data <payload>: <pin>², <start>², <length>, <data>^{<length>}

Description: As command 22h; but also facilitates the writing of protected E2 addresses.

Call: F0h_{10h}[<pin>², <start>², <length>, <data>^{<length>}]

Answer: F0h_{10h}[00h]

Response time: long

ATTENTION!! This command is provided exclusively for internal use by Lufft for the factory setting. Non-designated use can render the device unusable (see also page 6 Restricted Guarantee). This command is not intended to be used by the end user. The end user can attend to all the necessary settings on the device with the aid of the PC software provided by Lufft.

3.5.7 Online Data Request (23h)

Command <cmd>: 23h (NBC)
Command version <verc>: 1.0
Data <payload>: <channel>²

Description: A measurement value of a certain channel is requested with this command.

Call: 23h_{10h}[<channel>²]
Answer: 23h_{10h}[00h, <channel>², <type>, <value>ⁿ]

Response time: long

<channel>² designates the channel number

<type> designates the data type of the output; the length of <value> depends on this (see page 21 - Data Types)

<value>ⁿ requested value

Comment: The device description specifies the channel on which the transmission is to be made as well as the measurement value and format to be transmitted.

3.5.8 Multi-Channel Online Data Request (2Fh)

Command <cmd>: 2Fh (NBC)
Command version <verc>: 1.0
Data <payload>: <number>, <channel>²

Description: This command serves to request several channels with one call. A sub-telegram is transmitted for each channel.

Call: 2Fh_{10h}[<number>, <channel>² x <number>]

<number> number of channels requested

<channel>² designates the channel numbers

Answer: 2Fh_{10h}[00h, <number>, {<sub-len>, 00h, <channel>², <type>, <value>ⁿ}^{<number>}]

Response time: long

<sub-len> designates the number of bytes contained in this sub-telegram; if the subsequent status byte displays, for example, 'Value Overflow', <type> and <value>ⁿ are omitted and the next channel follows

<type> designates the data type of the output; the length of <value> depends on this (see page 21 - Data Types)

<value>ⁿ requested value

Comment: The device description specifies the channel on which the transmission is to be made as well as the measurement value and format to be transmitted. A maximum of 20 channels can be requested.

ATTENTION!! In the case of computing-intensive channels, such as the calculation of the mean average for wind in the ANACON, under certain circumstances the response time 'long' may not be sufficient for the transmission of several channels. If the sensor does not respond to the request, either the number of channels or the number of values in the mean value calculation must be reduced.

3.5.9 Offline Data Request (24h)

Command <cmd>: 24h (NBC)

Command version <verc>: 1.0

Not currently specified.

3.5.10 Reset / Default (25h)

Command <cmd>: 25h (BC)

Command version <verc>: 1.0

Data <payload>: <reset>

Description: This command triggers a software reset. Alternatively, a specified condition can be restored prior to the reset.

Call: 25h_{10h}[<reset>]

<reset> 10h triggers software reset
11h restore condition as delivered + software reset
12h restore device ID to condition as delivered + software reset
13h Device-specific command (see relevant specification)

Answer: 25h_{10h}[00h]

Comment: The answer takes place directly prior to the reset.

3.5.11 Reset with Delay (2Eh)

Command <cmd>: 2Eh (BC)

Command version <verc>: 1.0

Data <payload>: <delay>

Description: This command triggers a software reset after expiry of the delay period <delay> (e.g. for firmware update).

Call: 2Eh_{10h}[<delay>]

<delay> Delay period in seconds (max. 255)

Answer: 2Eh_{10h}[00h]

Comment: The answer takes place at the beginning of the delay period.

3.5.12 Status Request (26h)

Command <cmd>: 26h (NBC)

Command version <verc>: 1.0

Data <payload>: none

Description: Readout of the current status and/or error codes; thus the device can be asked if it is operating free from error.

Call: 26h_{10h}[]

Answer: 26h_{10h}[00h, <status>]

3.5.13 Last Error Message (2Ch)

Command <cmd>: 2Ch (NBC)

Command version <verc>: 1.0

Data <payload>: none

Description: Indicates the error code of the last response of the device with regard to communication. E.g. invalid parameter

Call: 2Ch_{10h}[]

Answer: 2Ch_{10h}[00h, <error>]

3.5.14 Set Time / Date (27h)

Command <cmd>: 27h (BC)
Command version <verc>: 1.0
Data <payload>: <unixtime>⁴

Description: Sets the date and time of the addressed device.

Call: 27h_{10h}[<unixtime>⁴]

Answer: 27h_{10h}[00h]

Comment: Unixtime is the 4 byte hexadecimal number with the lowest value byte (LSB) first, which corresponds to the seconds since 1.1.1970 0:00 UTC.

3.5.15 Readout Time / Date (28h)

Command <cmd>: 28h (NBC)
Command version <verc>: 1.0
Data <payload>: none

Description: Reads out the date and time of the addressed device.

Call: 28h_{10h}[]

Answer: 28h_{10h}[00h, <unixtime>⁴]

Comment: Unixtime is the 4 byte hexadecimal number with the lowest value byte (LSB) first, which corresponds to the seconds since 1.1.1970 0:00 UTC.

3.5.16 Test / Calibration Command (29h)

Command <cmd>: 29h (NBC)
Command version <verc>: 1.0
Data <payload>: <pin>², <function>, <data>ⁿ

Description: This command serves to calibrate and test the device

Call: 29h_{10h}[<pin>², <function>, <data>ⁿ]

Answer: 29h_{10h}[00h, ..., ...] (device-specific)

Response time: 2 x long !

ATTENTION!! This command is provided exclusively for internal use by Lufft for the factory setting. Non-designated use can render the device unusable (see also page 6 Restricted Guarantee). The test functions are contained in the device specification.

3.5.17 Monitor (2Ah)

Command <cmd>: 2Ah (NBC)
Command version <verc>: 1.0
Data <payload>: <monitor>ⁿ

Description: Device-specific functions can be executed through the PC software with the aid of monitor commands (see respective device specification).

Call: 29h_{10h}[<monitor command>ⁿ]

Answer: 29h_{10h}[00h, <answer>ⁿ]

Response time: long

ATTENTION!! This command is provided exclusively for internal use by Lufft for the factory setting. Non-designated use can render the device unusable.

This command is specified in the respective device specification.

3.5.18 Protocol Change (2Bh)

Command <cmd>: 2Bh (BC)

Command version <verc>: 1.0

Data <payload>: <type>

Description: Temporarily switches the device into another protocol.

Call: 2Bh_{10h}[<type>]

<type> 10h ASCII protocol

Answer: 2Bh_{10h}[00h]

ATTENTION!! Immediately following the answer, the device can only be addressed in the new protocol. If the device is required to operate again in, for example, binary mode, the corresponding command must be given for a change of protocol to binary mode.

The protocol changeover is **temporary!!** Following a reset or device-specific timeout the device communicates again in the previously set mode. If the device is to be operated permanently in, for example, ASCII mode, the device specification must be changed in the EEPROM.

3.5.19 Set New Device ID (30h)

Command <cmd>: 30h (BC)

Command version <verc>: 1.0

Data <payload>: <ID>²

Description: Gives the device a new ID.

Call: 30h_{10h}[<ID>²]

<ID>² new device ID (1 – 4095)

Answer: 30h_{10h}[00h]

ATTENTION!! A reset takes place immediately following the answer and after this the device can only be addressed with the new ID. Attention! This command is broadcastable. This enables devices of unknown ID to be provided with a new ID. However, this only makes reasonable sense if a maximum of one device is connected to the bus.

Command version <verc>: 1.1

Data <payload>: <ID>²

Description: Gives the device a **temporary** new ID.

Call: 30h_{11h}[<ID>²]

<ID>² new device ID (1 – 4095)

Answer: 30h_{11h}[00h]

ATTENTION!! A reset takes place immediately following the answer and after this the device can only be addressed with the new ID. Attention! This command is broadcastable. This enables devices of unknown ID to be provided with a new ID. However, this only makes reasonable sense if a maximum of one device is connected to the bus.

3.6 Status and Error Codes

Each response telegram contains a status byte. This gives information on the success or failure of the command. Further information is transmitted for certain error codes, which makes exact error analysis possible.

An error message is transmitted if a command was not processed successfully. This is constructed as follows:

<cmd>_{<verc>}[<status>, <info>ⁿ]

If there is no further information about a status, <info>ⁿ is omitted. In order that the frame control characters do not appear too often, 01h to 0Ah is dispensed with for these codes.

Codes:

<status>	<info>	Define	Description
00h (0d)		OK	Command successful; no error; all OK
10h (16d)		UNBEK_CMD	Unknown command; not supported by this device
11h (17d)		UNGLTG_PARAM	Invalid parameter
12h (18d)		UNGLTG_HEADER	Invalid header version
13h (19d)		UNGLTG_VERC	Invalid version of the command
20h (32d)		LESE_ERR	Read error
21h (33d)		SCHREIB_ERR	Write error
22h (34d)	<maxlength>	ZU_LANG	Length too great; max. permissible length is designated in <maxlength>
23h (35d)		UNGLTG_ADRESS	Invalid address / storage location
24h (36d)		UNGLTG_KANAL	Invalid channel
25h (37d)		UNGLTG_CMD	Command not possible in this mode
26h (38d)		UNBEK_CAL_CMD	Unknown calibration command
27h (39d)		CAL_ERROR	Calibration error
28h (40d)	<channel> ² ⁽¹⁾	BUSY	Device not ready; e.g. initialisation / calibration running
29h (41d)		LOW_VOLTAGE	Undervoltage
2Ah (42d)		HW_ERROR	Hardware error
2Bh (43d)		MEAS_ERROR	Measurement error
2Ch (44d)		INIT_ERROR	Error on device initialization
2Dh (45d)		OS_ERROR	Error in operating system
30h (48d)		E2_DEFAULT_KONF	Configuration error, default configuration was loaded
31h (49d)		E2_CAL_ERROR	Calibration error / the calibration is invalid, measurement not possible
32h (50d)		E2_CRC_KONF_ERR	CRC error on loading configuration; default configuration was loaded
33h (51d)		E2_CRC_KAL_ERR	CRC error on loading calibration; measurement not possible
34h (52d)		ADJ_STEP1	Calibration Step 1
35h (53d)		ADJ_OK	Calibration OK
36h (54d)		KANAL_AUS	Channel deactivated

⁽¹⁾info <channel>² only in command 'Online Data Request'

50h (80d)	<channel> ²	VALUE_OVERFLOW	Measurement variable (+offset) lies outside the set presentation range
51h (81d)	<channel> ²	VALUE_UNDERFLOW	
52h (82d)	<channel> ²	CHANNEL_OVERRANGE	Measurement value (physical) lies outside the measurement range (e.g. ADC overrange)
53h (83d)	<channel> ²	CHANNEL_UNDERRANGE	
54h (84d)	<channel> ²	DATA_ERROR	Data error in measurement data or no valid data available
FFh (255d)		UNBEK_ERR	Unknown error

3.7 Data Types

The following data types are used in this protocol, e.g. for the measurement value request:

<type>	Type Name	Define	Bytes	Range
10h (16d)	unsigned char	UNSIGNED_CHAR	1	0 ... 255
11h (17d)	signed char	SIGNED_CHAR	1	-128 ... 127
12h (18d)	unsigned short	UNSIGNED_SHORT	2	0 ... 65.535
13h (19d)	signed short	SIGNED_SHORT	2	-32.768 ... 32.767
14h (20d)	unsigned long	UNSIGNED_LONG	4	0 ... 4.294.967.295
15h (21d)	signed long	SIGNED_LONG	4	-2.147.483.648 ... 2.147.483.647
16h (22d)	float	FLOAT	4	$\pm 1.18E-38$... $\pm 3.39E+38$ (7 digits)
17h (23d)	double	DOUBLE	8	$\pm 2.23E-308$... $\pm 1.79E+308$ (15 digits)

Comment: float and double in IEEE format

3.8 Measurement Value Types

In this protocol the following measurement value types are used for the measurement value enquiry:

<type>	Type Name	Define	Description
10h (16d)	current	MWT_CURRENT	Current measurement value
11h (17d)	min	MWT_MIN	Minimum value
12h (18d)	max	MWT_MAX	Maximum value
13h (19d)	avg	MWT_AVG	Mean value
14h (20d)	sum	MWT_SUM	Sum
15h (21d)	vct	MWT_VCT	Vectorial mean value

3.9 Channel Assignment

A maximum of 65535 measurement channels can be addressed.

The channel assignment described here is applicable to the online data request in binary protocol. In ASCII protocol, all channels are transmitted in the mapping standard.

The current value transmits the currently measured value. In the case of the mean value, the measurement values are averaged over the time period specified in the configuration.

Attention: Not all devices in a device class deliver all of the channels described here. The exact channel assignment of the sensor used is described in the operating manual.

The summarisation of the channel assignments in this document serves for UMB devices of the same class to use the same channels for the same measurement variables and measurement ranges.

3.9.1 Channel Assignment – General Allocation

The following allocation of channels is recommended in order to identify the measurement variable more easily:

Channel	Measurement Variable
0 – 99	Reserved
100 – 199	Temperature
200 – 299	Humidity
300 – 399	Pressure (e.g. air)
400 – 499	Velocity (e.g. wind, flow)
500 – 599	Direction (e.g. wind)
600 – 699	Metric values (e.g. water film level in mm, visibility in m)
700 – 799	Logic conditions (e.g. door contact 0 / 1 = open / closed)
800 – 899	Relative measurement values (e.g. salt concentration)
900 – 999	Free
1000 – 1999	TLS codings (see also page 39 Chapter 5.3)
2000 – 2999	TLS codings for 2nd channel (e.g. ANACON)
10000 – 10099	Voltage
10100 – 10199	Current
10200 – 10299	Resistance
10300 – 10399	Frequency
10400 – 10499	Capacity
10500 – 10599	Pulses
20000 – 29999	Device-specific
65535	Reserved

3.9.2 Channel Assignment Device Class 1 Road Sensor

UMB Channel	Data Type	Measurement Variable	Measurement Range
Temperatures			
100	unsigned short	Road surface temperature in the mapping standard	0 ... 65520
101	float	Road surface temperature in °C	-40 ... +80 °C
102	float	Road surface temperature in °F	-40 ... +176 °F
110	unsigned short	Ground temperature depth 1 in the mapping standard	0 ... 65520
111	float	Ground temperature depth 1 in °C	-40 ... +80 °C
112	float	Ground temperature depth 1 in °F	-40 ... +176 °F
120	unsigned short	Ground temperature depth 2 in the mapping standard	0 ... 65520
121	float	Ground temperature depth 2 in °C	-40 ... +80 °C
122	float	Ground temperature depth 2 in °F	-40 ... +176 °F
Freezing temperature			
150	unsigned short	Freezing temperature in the mapping standard	0 ... 65520
151	float	Freezing temperature in °C	-40 ... 0 °C
152	float	Freezing temperature in °F	-40 ... +30 °F
Water film level			
600	unsigned short	Water film level in the mapping standard	0 ... 65520
601	unsigned short	Water film level in µm	0 ... 10000
602	float	Water film level in mil (= 1/1000 inch)	0 ... 393.7
Salt concentration			
800	unsigned short	Salt concentration in the mapping standard	0 ... 65520
801	float	Salt concentration in percent	0.0 ... 100.0 %
Road condition			
900	unsigned char	Defined road condition	0 ... 99
901	unsigned char	Physical road condition	0 ... 99
TLS channels see page 40 Supported TLS-DE Types FG3			

The respective mapping standards relate to the corresponding measurement range.

3.9.3 Channel Assignment Device Class 2 Rain Sensor

UMB Channel	Data Type	Measurement Variable	Measurement Range
current			
100	float	Ambient temperature in °C	-40°C...+80°C
101	float	Ambient temperature in °F	-40°F...+176°F
Precipitation type			
700	unsigned char	Type of precipitation (without unit)	0d = No precipitation 60d = Rain 67d = Freezing rain 69d = Sleet 70d = Snow 90d = Hail
Precipitation quantity			
600	double	Litre/m ²	0....100,000 litre/m ²
610	double	Water film level in mm per m ²	0....100 mm
620	double	Water film level in inches	0....3.937 Inch
630	double	Water film level in mil	0....3 937 008 mil
601	float	Litre/m ² since last request	0...100. litre/m ²
611	float	Water film level in mm since last request	0...100 mm
621	float	Water film level in inches since last request	0....3.937 inch
631	float	Water film level in mil since last request	0....3937 mil
1153	float	Precipitation intensity in inch/h Derived from channel 1053 (TLS code DE type 53 FG3)	0.....7.874 inch/h
1253	float	Precipitation intensity in mil/h Derived from channel 1053 (TLS code DE type 53 FG3)	0.....7 874 mil/h
TLS channels see page 40 Supported TLS-DE Types FG3			

The channel list is not yet complete and further additions will be made.

3.9.4 Channel Assignment Device Class 3 Visibility Sensor

UMB Channel		Data Type	Measurement Variable	Measurement Range
Current	Mean			
Visibility				
600	650	float	in metres	10 – 1000 metres
601	651	float	in metres	10 – 2000 metres
602	652	float	in kilometres	0.01 – 1.000 km
603	653	float	in kilometres	0.01 – 2.000 km
604	654	float	in feet	32 – 3000 feet
605	655	float	in feet	32 – 6500 feet
606	656	float	in miles	0.006 – 0.600 miles
607	657	float	in miles	0.006 – 1.200 miles
608	658	unsigned short	in the mapping standard	20 – 4000
Ambient temperature				
100	150	float	in °C	-40 - +80 °C
101	151		in °F	-40 - +176 °F
102	152	unsigned short	in the mapping standard	
TLS channels see page 40 Supported TLS-DE Types FG3				

Mapping Standards

Mapping Standard	Visibility Value Range
0 – 65520	0 – 32760 m
	0 – 32.76 km
	0 – 107480.315 feet
	0 – 20.3561203 miles
	Ambient Temperature Value Range
	-40 - +80 °C
	-40 - +176 °F

3.9.5 Channel Assignment Device Class 4 Temperature/Humidity

UMB Channel		Data Type	Measurement Variable	Measurement Range
Current	Mean			
Temperature				
Humidity				
TLS channels see page 40 Supported TLS-DE Types FG3				

The channel list is not yet complete and further additions will be made.

3.9.6 Channel Assignment Device Class 5 Wind Sensor

UMB Channel		Data Type	Measurement Variable	Measurement Range
Current	Mean			
Wind Direction				
Wind Speed				
TLS channels see page 40 Supported TLS-DE Types FG3				

The channel list is not yet complete and further additions will be made.

3.9.7 Channel Assignment Device Class 6 Universal Measurement Transmitter

UMB Channel				Special	Input	Variable	Measurement Range		
Current	Min	Max	Avg				Min	Max	Unit
Temperature									
100	120	140	160		A	Temperature	-200.0	450.0	°C
105	125	145	165		A	Temperature	-328.0	842.0	°F
110	130	150	170			Dewpoint	-200.0	450.0	°C
111	131	151	171			Dewpoint	-328.0	842.0	°F
Humidity									
201	221	241	261		B	Relative Humidity	0.0	100.0	%
206	226	246	266		B	Absolute Humidity			g/m ³
211	231	251	271		B	Mixing Ratio			g/kg
Pressure									
300	320	340	360		A	Abs. Air Pressure	0	1200	hPa
305	325	345	365		A	Rel. Air Pressure	0	1200	hPa
301	321	341	361		B	Abs. Air Pressure	0	1200	hPa
306	326	346	366		B	Rel. Air Pressure	0	1200	hPa
Wind									
				Vect. Avg					
400	420	440	460	480	A	Wind Speed	0	100.0	m/s
405	425	445	465	485	A	Wind Speed	0	360.0	km/h
410	430	450	470	490	A	Wind Speed	0	223.7	mph
415	435	455	475	495	A	Wind Speed	0	194.4	kts
501	521	541	561	581	B	Wind Direction	0	359.9	°
Precipitation									
600					A	Precipitation absol.			mm
601					B	Precipitation absol.			mm
620					A	Precipitation diff.			mm
621					B	Precipitation diff.			mm
640					A	Precip. intens.			mm/h
641					B	Precip. intens.			mm/h
Digital Input									
700	720	740	760		A	Digital Input	0	1	
701	721	741	761		B	Digital Input	0	1	
Voltage									
10000	10020	10040	10060		A	Voltage	0	1000	mV
10001	10021	10041	10061		B	Voltage	0	1000	mV
Current									
10100	10120	10140	10160		A	Current	0	24	mA
10101	10121	10141	10161		B	Current	0	24	mA
Resistance									
10200	10220	10240	10260		A	Resistance	0	2000	Ohm
10201	10221	10241	10261		B	Resistance	0	2000	Ohm
Frequency									
10300	10320	10340	10360		A	Frequency	10	10000	Hz
10301	10321	10341	10361		B	Frequency	10	10000	Hz
Pulses									
10500					A	Pulses absol.	0	65520	pulse
10501					B	Pulses absol.	0	65520	pulse
10520					A	Pulses diff.	0	65520	pulse
10521					B	Pulses diff.	0	65520	pulse

TLS channels see page 40 Supported TLS-DE Types FG3

Attention: The channels which are actually available depend on the configuration.

3.9.8 Channel Assignment Device Class 7 Compact Weather Station

UMB Channel						Measurement Range		
current	min	max	avg	special	measurement variable	min	max	unit
Temperature								
100	120	140	160		temperature	-200.0	450.0	°C
105	125	145	165		temperature	-328.0	842.0	°F
110	130	150	170		dewpoint	-200.0	450.0	°C
115	135	155	175		dewpoint	-328.0	842.0	°F
Humidity								
200	220	240	260		relative humidity	0.0	100.0	%
205	225	245	265		absolute humidity			g/m ³
210	230	250	270		mixing ratio			g/kg
Pressure								
300	320	340	360		abs. air pressure	0	1200	hPa
305	325	345	365		rel. air pressure	0	1200	hPa
Wind								
				vect. avg				
400	420	440	460	480	wind speed	0	100.0	m/s
405	425	445	465	485	wind speed	0	360.0	km/h
410	430	450	470	490	wind speed	0	223.7	mph
415	435	455	475	495	wind speed	0	194.4	kts
500	520	540	560	580	wind direction	0	359.9	°
TLS channels see page 40 Supported TLS-DE Types FG3								

Precipitation type			
700	Unsigned char	No unit	0 = No precipitation 60 = Rain 70 = Snow
Precipitation quantity			
600	double	Liter / m ²	0....100 000 liter/m ²
620	double	Water film height in mm	0....100 000 mm
640	double	Water film height in inches	0....3937 inch
660	double	Water film height in mil	0....3 937 008 mil
605	float	Liter/m ² since last request	0...100. liter/m ²
625	float	Water film height in mm since last request	0...100 mm
645	float	Water film height in inches since last request	0....3.937 inch
665	float	Water film height in mil since last request	0....3937 mil
TLS channels see page 40 Supported TLS-DE Types FG3			

Note: The channels actually available depend on the compact weather station type.

3.9.9 TLS Channel Assignment

These channels are provided for the transmission of data corresponding to the TLS types per TLS2002 DE-FG3 (weather and environment data). The channel numbers correspond to DE types FG3 with an offset of 1000 (see also 5.3 Data Types in UMB Products per TLS2002 FG3).

E.g. Visibility:

FG3 DE-Type 60 Result Message Visibility SW Channel 1060

3.10 Units List

The following units are used for measurement values for all UMB products. These are transmitted, among other occasions, at the time when the device information is transmitted.

3.10.1 Temperature

Unit	Description	Comment
°C	Degrees Celsius	
°F	Degrees Fahrenheit	
K	Kelvin	

3.10.2 Humidity

Unit	Description	Comment
%rH	Relative Humidity	
g/kg	Absolute Humidity	
g/m ³	Absolute Humidity	

3.10.3 Lengths

Unit	Description	Comment
µm	Micrometres	
mm	Millimetres	
cm	Centimetres	
dm	Decimetres	
m	Metres	
km	Kilometres	
in	Inches	1 inch = 25.4 mm
mil	Milli-inches	1 mil = 1/1000 inch = 0.0254 mm
ft	Foot, feet	1 foot = 0.3048 Meter
mi	Miles	1 US statute mile = 1.609344 km

3.10.4 Velocities

Unit	Description	Comment
m/s	Metres per second	
km/h	Kilometres per hour	
mph	Miles per hour	One mph corresponds to 1.609344 km/h or 0.44704 m/s
kts	Knots	1 knot = 1 sea mile/hour = 1.852 km/h = 0.51444 m/s

3.10.5 Electrical Variables

Unit	Description	Comment
mV	Millivolts	
V	Volts	
mA	Milliamperes	
A	Amperes	

3.10.6 Frequency

Unit	Description	Comment
Hz	Hertz	
kHz	Kilohertz	

3.10.7 Pressure

Unit	Description	Comment
bar	Bars	
mbar	Millibars	
Pa	Pascals	
mPa	Millipascals	
hPa	Hectopascals	

3.10.8 Volumes

Unit	Description	Comment
m ³	Cubic metres	
l	Litres	

3.10.9 Time

Unit	Description	Comment
s	Seconds	
µs	Microseconds	

3.10.10 Miscellaneous

Unit	Description	Comment
%	Percent	Relative proportion
°	Degree	Angle details
mm/h	Millimetres per hour	Precipitation intensity
l/m ²	Litres per square metre	Precipitation quantity

Character set is coded in accordance with the ANSI table (German). See also page 46

3.11 Example of a Binary Protocol Request

If, for example, the hardware and software version of a visibility sensor with the device ID (serial number) 0423 is to be requested by a PC, this takes place as follows:

Sensor:

Class ID for **visibility sensor** is 3 = 3h

Device ID (serial number) is 0423 = 1A7h

Putting class and device ID's together results in a target address of 31A7h

PC:

Class ID for **PC (master device)** is 15 = Fh

PC-ID is e.g. 22 = 016h

Putting class and PC ID's together results in a sender address of F016h

The length <len> of the "request hardware and software version" command is 2d = 02h, as the command consists of only 2 bytes

The command for "request hardware and software version" is 20h

The version number of the command is 1.0 = 10h

The command has no <payload>

The CRC is 67BBh

The complete request to the device:

SOH	<ver>	<to>		<from>		<len>	STX	<cmd>	<verc>	ETX	<cs>		EOT
1	2	3	4	5	6	7	8	9	10	11	12	13	14
01h	10h	A7h	31h	16h	F0h	02h	02h	20h	10h	03h	BBh	67h	04h

The complete answer from the device:

SOH	<ver>	<to>		<from>		<len>	STX	<cmd>	<verc>	<status>	<HW>	<SW>	ETX	<cs>		EOT
1	2	3	4	5	6	7	8	9	10	11	12	13	14	15	16	17
01h	10h	16h	F0h	A7h	31h	05h	02h	20h	10h	00h	10h	17h	03h	E0h	DDh	04h

Thus the device has hardware version 10h = 16d = V1.6 and software version 2.3.

The correct data transmission can be checked with the aid of the checksum (DDE0h).

ATTENTION: Little endian (Intel, lowbyte first) applies to the transmission of word variables, e.g. device addresses. This means first the LowByte and then the HighByte.

3.12 Comments about Broadcast

If a device is addressed directly with class and device ID, the answer described in the command is returned.

If a device is addressed with broadcast (class or device ID '0'), the command is **NOT** answered, as in the case of broadcast it must be assumed that several units are addressed simultaneously and there would otherwise be collisions.

Not all commands are broadcastable, as it makes no sense, for example, to send a measurement value request to all devices because they do not answer in the case of a broadcast. 'BC' identifies whether a command is broadcastable. 'NBC' stands for not broadcastable.

A sensible application of broadcast commands is, for example, the setting of date and time. In doing so, the entire network can be updated with a single telegram.

4 UMB ASCII Protocol

It is possible to communicate easily with devices in the 'read only' mode via the ASCII protocol. However, configuration can only be carried out via the binary protocol.

The ASCII protocol serves exclusively for online data requests and is not secured via a CRC. The device does not react to incomprehensible ASCII commands.

No TSL channels are available in the ASCII protocol.

4.1 Construction

An ASCII command is introduced by the character '&' and ended with the character CR (0Dh). There is a blank character (20h) between the individual blocks in each case; represented with an underscore '_'. Characters which represent an ASCII value are in simple quotation marks.

4.1.1 Summary of the ASCII Commands

Command	Function	BC	RT	IRS21CON	VS20	R2S	ANACON	WSx	IRS31
M	Online request		l	●	●		●		
X	Changes to the binary protocol		s	●	●		●		
R	Triggers software reset	●	s	●	●		●		
D	Reset with delay	●	s	●	●		●		
I	Device information		s	●	●		●		

4.1.2 Online Data Request (M)

Description: This command serves to request a measurement value of a specific channel.

Call: '&'_<ID>⁵'M'_<channel>⁵ CR

Answer: '\$'_<ID>⁵'M'_<channel>⁵'_<value>⁵ CR

<ID>⁵ device address (5 position decimal with leading noughts)

<channel>⁵ designates the channel number (5 position decimal with leading noughts)

<value>⁵ measurement value (5 position decimal with leading noughts); a measurement value standardised to 0 – 65520d. Various error codes are defined from 65521d – 65535d

Example:

Call: &_04519_M_00001

With this call, channel 1 is requested by the device with the address 4591 (road sensor with the device ID 0423; see page 10).

Answer: \$_04519_M_00001_36789

Assuming that this channel gives a temperature from –20 to +100°C, the following computation results:

0d	corresponds to	-20°C
65520d	corresponds to	+100°C
36789d	corresponds to	[+100°C – (-20°C)] / 65520 * 36789 +(-20°C) =
47.379°C		

Comment: The device description specifies the channel on which the transmission is to be made as well as the measurement value and standardisation format to be transmitted.

Attention: TLS channels are not available in the ASCII protocol.

4.1.3 Protocol Change (X)

Description: This command serves to switch temporarily into the binary mode.

Call: '&_'<ID>_'X' CR

Answer: '\$_'<ID>_'X' CR

<ID>⁵ Device address (5 position decimal with leading noughts)

Comment: ATTENTION!! Immediately following the answer, the device can only be addressed in binary protocol. If the device is required to operate again in ASCII mode, the binary command must be given for a change of protocol to ASCII mode.

The protocol changeover is **temporary!!** Following a reset or device-specific timeout the device communicates again in the previously set mode. If the device is to be operated permanently in, for example, binary mode, the device specification must be changed in the EEPROM.

4.1.4 Reset / Default (R)

Description: This command serves to trigger a software reset. Alternatively, the delivered condition can be restored prior to the reset.

Call: '&_'<ID>_'R'<reset> CR

Answer: '\$_'<ID>_'R' CR

<ID>⁵ Device address (5 position decimal with leading noughts)

<reset>³ 010: Reset; 011: Reset with default

Comment: The answer takes place immediately before the reset.

4.1.5 Reset with Delay (D)

Description: This command serves to trigger a software reset after expiry of the delay period <delay> (e.g. for firmware update).

Call: '&_'<ID>_'D'<delay> CR

Answer: '\$_'<ID>_'D' CR

<ID>⁵ Device address (5 position decimal with leading noughts)

<delay>³ Delay time in seconds (max. 255)

Comment: The answer takes place at the beginning of the delay time.

4.1.6 Device Information (I)

Description: This command serves to switch into the binary mode.

Call: '&_'<ID>_'I' CR

Answer: '\$_'<ID>_'I'<SerNo>_<MMYY>_<Project>_<PartsList>_<PartsPlan>_<hardware>_<software>_<e2version>_<DeviceVersion> CR

<ID>⁵ Device address (5 position decimal with leading noughts)

4.2 Error Codes in the ASCII Protocol

Various error codes are defined from 65521d – 65535d in addition to the standardisation for the transmission of measurement values.

Codes:

<code>	Description
65521d	Invalid Channel
65522d	
65523d	Value Overflow
65524d	Value Underflow
65525d	
65526d	
65527d	
65528d	
65529d	
65530d	
65531d	
65532d	
65533d	
65534d	Invalid Calibration
65535d	Unknown Error

5 Appendix

5.1 CRC Calculation

The CRC is calculated in accordance with the following rules:

Norm: CRC-CCITT

Polynomial: $1021h = x^{16} + x^{12} + x^5 + 1$ (LSB first mode)

Start value: FFFFh

(Attention! In contrast to earlier Lufft protocols, the start value for the CRC calculations in this case is not 0h but FFFFh in accordance with CCITT)

5.1.1 Example of a CRC-CCITT Calculation in C

If the CRC calculation is to be made for several bytes, the previously calculated CRC must be buffered in an unsigned short variable (which must be initialised at FFFFh at the beginning of a test sequence).

```

/*****
Function:      16 bit CRC-CCITT calculation
-----
Call:         calc_crc(unsigned short crc_buff, unsigned char input)
-----
Response:     Newly calculated 16 bit CRC checksum
-----
Description:  Calculates the checksum for 'input' in accordance with the
              CRC polynomial  $x^{16} + x^{12} + x^5 + 1$ .
              'crc_buff' is the previously calculated checksum. This must
              be set to 0xFFFF at the beginning of a test sequence.
*****/
unsigned short calc_crc(unsigned short crc_buff, unsigned char input)
{
    unsigned char i;
    unsigned short x16; // we'll use this to hold the XOR mask
    for (i=0; i<8; i++)
    {
        // XOR current D0 and next input bit to determine x16 value
        if( (crc_buff & 0x0001) ^ (input & 0x01) )
            x16 = 0x8408;
        else
            x16 = 0x0000;
        // shift crc buffer
        crc_buff = crc_buff >> 1;
        // XOR in the x16 value
        crc_buff ^= x16;
        // shift input for next iteration
        input = input >> 1;
    }
    return(crc_buff);
}

```

```

// ***** MAIN *****
void main(void)
{
    // example: CRC for 8 Bytes
    unsigned char values[8] =
        {0x30, 0x31, 0x32, 0x33, 0x34, 0x35, 0x36, 0x37};
    // initialise startvalue FFFFh
    unsigned short crc = 0xFFFF;
    // calculation
    for(int n = 0; n < 8; n++)
    {
        crc = calc_crc(crc, values[n]);
    }
    // output
    printf("\ndata:  30h, 31h, 32h, 33h, 34h, 35h, 36h, 37h");
    printf("\nCRC:   %04Xh\n", crc);
}

```

Output:

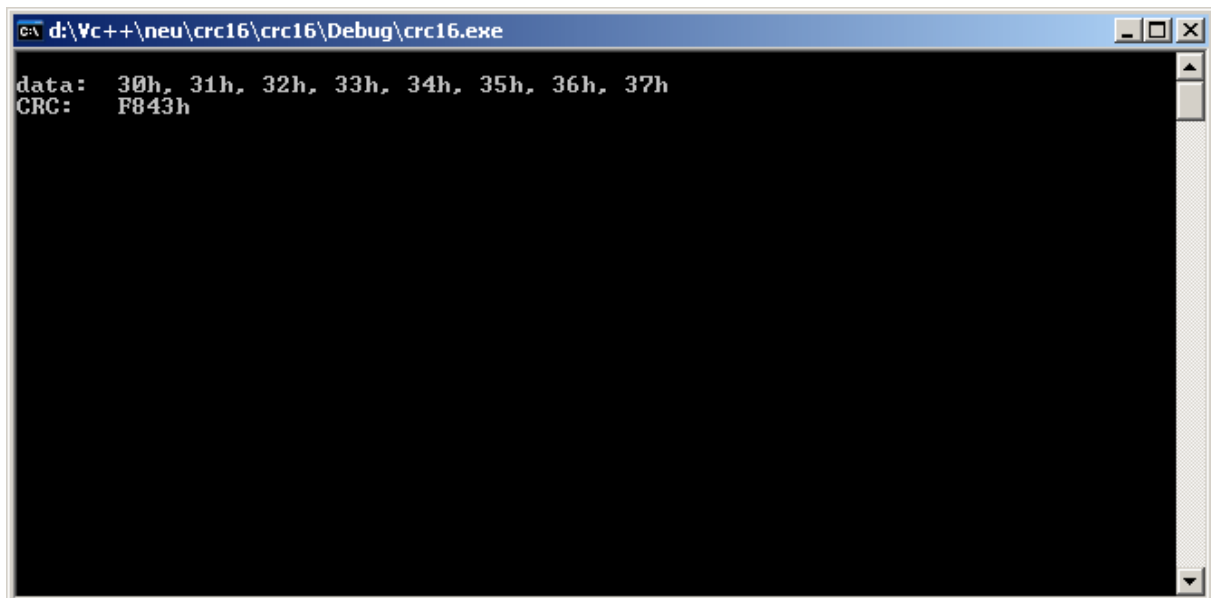

```

c:\ d:\Vc++\neu\crc16\crc16\Debug\crc16.exe
data:  30h, 31h, 32h, 33h, 34h, 35h, 36h, 37h
CRC:   F843h

```

5.2 Automatic Readout of a Network

This section describes a mechanism which makes it possible to analyse an existing network and thereby configure the master software.

5.2.1 Background

As this is a half-duplex network on RS485 basis without collision recognition, the master-slave principle must be observed. In order to scan a network, the master would have to scan the entire address space which, with more than 30,000 possible addresses, would take too long.

Instead of this, the system is configured in the way described below in order for the master software to be able to scan the network in a short period of time.

5.2.2 Necessary ID Configuration of the Sensors

The sensors are provided with device ID's per network and device class, beginning at 1. This also corresponds to the delivered condition. Additional sensors in a device class are provided with ID's in ascending order (2, 3, 4, 5).

Example:

Sensors	Class ID	Recommended Device ID
Road sensor 1	1	1
Road sensor 2	1	2
Rain sensor 1	2	1
Rain sensor 2	2	2
Visibility sensor 1	3	1
Visibility sensor 2	3	2
Temperature/Humidity 1	4	1
Temperature/Humidity 2	4	2
Temperature/Humidity 3	4	3
Wind 1	5	1

As the different sensors have different class ID's and the address is made up of class ID and device ID, each subscriber has its own address.

5.2.3 Scanning the Network

When scanning, the master begins to poll the sensors in ascending order of class and device ID. For this purpose, a command is used which is understood by each sensor; e.g. status request (26h).

The device ID is increased until no further reply is received to the status request. The class ID is then incremented, beginning again with device ID 1.

5.3 Data Types in UMB Products per TLS2002 FG3

The transmission of TLS data is based on the DE block structure. The TLS output is limited to the TLS-compliant data standardisation per FG3. The answer to a measurement value request for TLS data contains the UMB channel and the measurement value. The UMB channels receive an offset of +1000 compared with DE type FG3. For multi-channel devices the offset increases by 1000 respectively.

8 bit measurement value:

Position	Designation	Explanation
Byte 1	Measurement value	

16 bit measurement value:

Position	Designation	Explanation
Byte 1	Measurement value	low Byte
Byte 2	Measurement value	high Byte

5.3.1 Example of a TLS Measurement Value Request

A visibility measuring device is to transmit the visibility in accordance with TLS (16 bit measurement value).

DE type 60 (SW) gives UMB channel 1060 = 0424h

Call: 23h_{10h}[<channel>²]
 23h_{10h}[24h, 04h]

Answer: 23h_{10h}[00h, <channel>², <low byte>, <high byte>]
 23h_{10h}[00h, 24h, 04h, E8h, 03h]

High Byte = 03h; Low Byte = E8h; gives 03E8h = 1000d = 1000 metres visibility

5.3.2 Supported TLS-DE Types FG3

DE Type	UMB Channel	Meaning	Format	Range	Res.	Coding
Device Class 1 Road Sensor						
49	1049	Result message Road Surface Temperature RST	16 bit	-30...+80°C	0.1°C	80.0 = 800d = 0320h 0.0 = 0d = 0000h -0.1 = -1d = FFFFh -30.0 = -300d = FED4h
52	1052	Result message Residual Salt RS	8 bit	0%...100%	1%	0% = 0d = 00h 100% = 100d = 64h FFh = not definable
65	1065	Result message Freezing Temperature FT	16 bit	-30...0 °C	0.1°C	0.0 = 0d = 0000h -0.1 = -1d = FFFFh -30.0 = -300d = FED4h
67	1067	Result message Temperature at Depth 1 TD1	16 bit	- 30 ... + 80 °C	0.1 °C	80.0 = 800d = 0320h 0.0 = 0d = 0000h -0.1 = -1d = FFFFh -30.0 = -300d = FED4h
68	1068	Result message Temperature at Depth 2 TD2	16 bit	- 30 ... + 80 °C	0.1 °C	see TT1
70	1070	Result message Road Surface Condition (RSC)	8 bit	0 ... 255		see 5.3.3
72	1072	Result message Water Film Level WFL	16 bit	0.00...10.00 mm	0.01 mm	0 = 0d = 0000h 10,00 = 1000d = 03E8h FFFFh = not definable
Device Class 2 Rain Sensor						
53	1053	Result message Precipitation Intensity PI	16 bit	0 ... 200 mm/h	0.1 mm/h	0.0 = 0d = 0000h 200.0 = 2000d = 07D0h
71	1071	Result message Precipitation Type PT	8 bit	0 ... 255		0d = No precipitation 60d = Rain (including freezing rain and sleet) 70d = Snow (including hail) see also 5.3.4
Device Class 3 Visibility Sensor						
60	1060	Result message Visibility V	16 bit	10 ... 1000 m	1 m	10 = 10d = 000Ah 1000 = 1000d = 03E8h
Device Class 4 Temperature/Humidity						
Device Class 5 Wind Sensor						

DE Type	UMB Channel	Meaning	Format	Range	Res.	Coding
Device Class 6 Universal Measurement Transmitter e.g. ANACON (Channel assignment is configuration-dependent)						
48	1048	Result message Air Temperature AT	16 bit	-30 ... +60°C	0.1°C	60.0 = 600d = 0258h 0.0 = 0d = 0000h -0.1 = -1d = FFFFh -30.0 = -300d = FED4h
53	1053	Result message Precipitation Intensity PI CH1	16 bit	0 ... 200 mm/h	0.1 mm/h	0.0 = 0d = 0000h 200.0 = 2000d = 07D0h
	2053	Result message Precipitation Intensity PI CH2				
54	1054	Result message Air Pressure AP CH1	16 bit	800...1200 hPa	1 hPa	800 = 800d = 0320h 1200 = 1200d = 04B0h
	2054	Result message Air Pressure AP CH1				
55	1055	Result message Relative Humidity RH	8 bit	10% ... 100%	1% RH	10% = 10d = 0Ah 100% = 100d = 64h
56	1056	Result message Wind Direction WD	16 bit	0 ... 359°	1°	0° (N) = 0d = 0000h 90° (O) = 90d = 005Ah 180° (S) = 180d = 00B4h 270° (W) = 270d = 010Eh FFFFh = not definable
57	1057	Result message Wind Speed (mean value) WSM	16 bit	0.0 ... 60.0 m/s	0.1 m/s	0.0 = 0d = 0000h 60.0 = 600d = 0258h
64	1064	Result message Wind Speed (peak value) WSP	16 bit	0.0 ... 60.0 m/s	0.1 m/s	0.0 = 0d = 0000h 60.0 = 600d = 0258h
66	1066	Result message Dewpoint Temperature DPT	16 bit	-30 ... +60°C	0.1°C	60.0 = 600d = 0258h 0.0 = 0d = 0000h -0.1 = -1d = FFFFh -30.0 = -300d = FED4h
140	1140	Operating message Door Contact DC CH1	8 bit	0 ... 1	1	see 5.3.5
	2140	Operating message Door Contact DC CH2				

For DE types which can be measured on both measurement channels of the ANACON, the UMB channel offset for CH1 DE type is +1000 and for CH2 DE type + 2000

DE Type	UMB Channel	Meaning		Range	Resolution	Coding
Device Class 7 Compact Weather Station e.g. WSx (channel assignment depends on configuration)						
48	1048	Result message Air temperature AT	16 bit	-30 ... +60°C	0.1°C	60.0 = 600d = 0258h 0.0 = 0d = 0000h -0.1 = -1d = FFFFh -30.0 = -300d = FED4h
53	1053	Result message Precipitation intensity PI	16 bit	0 ... 200 mm/h	0.1 mm/h	0.0 = 0d = 0000h 200.0 = 2000d = 07D0h
54	1054	Result message Air pressure AP	16 bit	800...1200 hPa	1 hPa	800 = 800d = 0320h 1200 = 1200d = 04B0h
55	1055	Result message Relative humidity RH	8 bit	10% ... 100%	1% rF	10% = 10d = 0Ah 100% = 100d = 64h
56	1056	Result message Wind direction WD	16 bit	0 ... 359°	1°	0° (N) = 0d = 0000h 90° (O) = 90d = 005Ah 180° (S) = 180d = 00B4h 270° (W) = 270d = 010Eh FFFFh = not definable
57	1057	Result message Wind speed (mean value) WSM	16 bit	0.0 ... 60.0 m/s	0.1 m/s	0.0 = 0d = 0000h 60.0 = 600d = 0258h
64	1064	Result message Wind speed (peak value) WSP	16 bit	0.0 ... 60.0 m/s	0.1 m/s	0.0 = 0d = 0000h 60.0 = 600d = 0258h
66	1066	Result message Dewpoint temperature DT	16 bit	-30 ... +60°C	0.1°C	60.0 = 600d = 0258h 0.0 = 0d = 0000h -0.1 = -1d = FFFFh -30.0 = -300d = FED4h
71	1071	Result message Precipitation type PT	8 bit			0 = No rain 60 = Rain (including freezing rain and sleet) 70 = Snow (including hail)

Derived variables

1153	float	Precipitation intensity in inch/h Derived from channel 1053 (TLS code DE type 53 FG3)	0.....7.874 inch/h
1253	float	Precipitation intensity in mil/h Derived from channel 1053 (TLS code DE type 53 FG3)	0.....7 874 mil/h

5.3.3 DE Type 70 “Road Surface Condition” (RSC)

Content / Characteristics	Definition
0	Road is completely dry (< approx. 30 ml/m ² = 0.03 mm), free of snow and ice
1	Road is moist or wet or covered in snow or ice. The wetness or coverage is greater than approx. 30 ml/m ² = 0.03 mm. No further differentiation of the type of coverage is possible.
2 ... 31	Free for extensions
32	Road is wet with liquid water or watery solution. The quantity is greater than approx. 30 ml/m ² = 0.03 mm No further differentiation is possible.
33 ... 63	Free for extensions
64	Road is covered with freezing water or watery solution in solid form. No further differentiation is possible.
65	Road is covered with snow or slush. Mixture of liquid and frozen water or watery solution.
66	Road is covered with ice (solid, frozen water or frozen watery solution).
67	Road is covered with frost. Ice crystals sublimated from the air without covering surface with ice. The dewpoint temperature is close to the road surface temperature and below the freezing temperature.
68 ... 127	Free for extensions
128 ... 254	Free for codes specific to the manufacturer or user.
255	The sensors are unable to determine the status due to the prevailing conditions.

It should be noted in relation to the road section that the measurement can only ever be at one specific point and the results must therefore be interpreted accordingly.

Wetness and coverage always relate to a smooth, even surface. The estimate concerning the hazardousness of wetness or coverage in relation to the condition of the road surface (unevenness etc.) and the specific conditions of the section of road in question must be made at the control centre.

It is not necessary for the sensor technology to be able to directly detect all of the conditions. Rather, it is sufficient that the influences contributing to the formation of the conditions can be measured in order that the condition in question can be assumed to be probable.

It is not necessary for all characteristics to be supported by a road measuring station.

The degree of wetness or coverage, as far as can be defined, is indicated by the “water film level” (mm or l/m²).

5.3.4 DE Type 71 “Precipitation Type” (PT)

Content / Characteristics	Definition
All	Precipitation falling in the atmosphere. If precipitation intensity is to be determined, this is carried out at the same location. The classification and codes are used in accordance with WMO Table 4680.
0	No precipitation
1 ... 39	Do not use
40	Precipitation of all types Cannot be classified or quantified further or sensors not designed for this purpose.
41	Light or average precipitation of all types (< 50 particles per minute)
42	Heavy precipitation of all types (> 50 particles per minute)
43 ... 49	Free for extensions
50	Drizzle (no further classification of drizzle is possible)
51 ... 59	Further classification of drizzle per WMO
60	Rain or liquid precipitation (no further classification of rain is possible)
61 ... 69	Further classification of rain per WMO
70	Snow or frozen precipitation (no further classification of frozen precipitation is possible)
71 ... 73	Further classification of snow per WMO
74 ... 76	Further classification of graupel per WMO
77 ... 79	Further classification of hail per WMO
80 ... 127	Free for extensions
128 ... 254	Free for codes specific to the manufacturer or user.
255	The sensors are unable to determine the status due to the prevailing conditions.

It should be pointed out that not all characteristics require to be supported by the road measuring station or sensor technology. The degree of differentiation which is necessary and reasonable depends on the application. For simple applications, characteristics 0 and 40 may be sufficient; for normal requirements 0, 60 and 70 (corresponds to the characteristics 00, 01 and 02 of type 63 used previously).

5.3.5 DE Type 140 “Door Contact” (DC)

As this system is limited to FG3 data but the door contact is defined in FG6 as DE type 48, DE type 140 is used as a door contact message in FG3 if this message is to be present as the only operating message.

DE Type	Channel	Meaning	Format	Range	Res.	Coding
140	1140 2140	Operating message Door Contact DC	8 bit	0 ... 1	1	00 = 0d = 00h 01 = 1d = 01h

Content		Switch Contact
0	Door closed	open
1	Door open	closed

5.3.6 DE Type 140 Inverted “Door Contact” (DC)

DE Type	UMB Channel	Meaning	Format	Range	Res.	Coding
140	1145 2145	Operating message Inverted Door Contact DC	8 bit	0 ... 1	1	00 = 0d = 00h 01 = 1d = 01h

	Definition	Switch Contact
0	Door closed	closed
1	Door open	open

5.4 Character Table for Text Editions

The output of the characters for text editions of all types takes place in accordance with the ASCII Code Table (Codetabelle) with the extension per ISO-8859-1 (Latin-1):

ASCII-Codetabelle										
+	0	1	2	3	4	5	6	7	8	9
30			!	"	#	\$	%	&	'	
40	()	*	+	,	-	.	/	0	1
50	2	3	4	5	6	7	8	9	:	;
60	<	=	>	?	@	A	B	C	D	E
70	F	G	H	I	J	K	L	M	N	O
80	P	Q	R	S	T	U	V	W	X	Y
90	Z	[\]	^	_	`	a	b	c
100	d	e	f	g	h	i	j	k	l	m
110	n	o	p	q	r	s	t	u	v	w
120	x	y	z	{		}	~			

iso-8859-1										
+	0	1	2	3	4	5	6	7	8	9
160		ı	φ	£	κ	¥	ı	š	ˆ	ø
170	æ	«	¬	-	ø	-	°	±	²	³
180	˘	µ	¶	·	¸	¹	º	»	¼	½
190	¸	ı	À	Á	Â	Ã	Ä	Å	Æ	Ç
200	È	É	Ê	Ë	Ì	Í	Î	Ï	Ð	Ñ
210	Ò	Ó	Ô	Õ	Ö	×	Ø	Ù	Ú	Û
220	Ü	Ý	Þ	ß	à	á	â	ã	ä	å
230	æ	ç	è	é	ê	ë	ì	í	î	ï
240	ð	ñ	ò	ó	ô	õ	ö	÷	ø	ù
250	ú	û	ü	ý	þ	ÿ				