

Ventus Ultrasonic Wind Sensor

Operational Manual

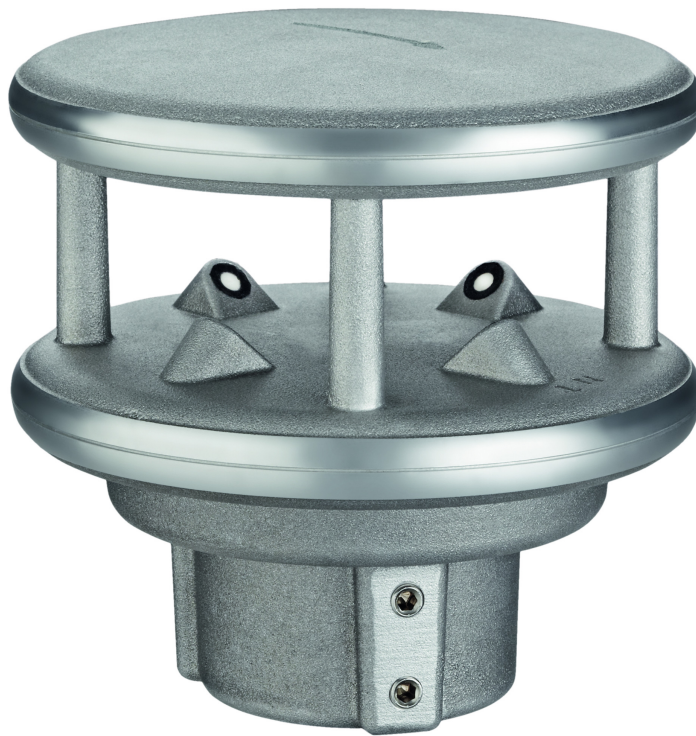

Copyright © OTT HydroMet Fellbach GmbH

OTT HydroMet Fellbach GmbH
Gutenbergstr. 20
70736 Fellbach
Germany

+49 711 51822 -0
met-info@otthydromet.com
www.otthydromet.com

All rights reserved.

All content is the intellectual property of OTT HydroMet. Reprinting, duplication and translation (even as excerpts) are only permitted with the prior written consent of OTT HydroMet.

Subject to technical change.

Table of contents

1	Scope of supply	6
2	Order numbers and variant code	7
2.1	Product variants	7
2.2	Accessories	7
3	About this manual	8
3.1	Other applicable documents and software	8
3.2	General signs and symbols	8
3.3	Explanation of warnings	9
4	General safety instructions	10
4.1	Intended use	10
4.2	Potential misuse	10
4.3	Personnel qualification	10
4.4	Operator obligations	10
4.5	Personnel obligations	10
4.6	Correct handling	10
4.7	Health hazards	11
4.7.1	Risk of electrical shock	11
4.8	Working outdoor	11
4.8.1	Installation and maintenance at great heights	11
4.8.2	Using long cables	11
4.8.3	Working at roadside	11
4.9	Certification	11
4.9.1	Europe, USA and Canada	11
4.9.2	Safety	12
5	Product description	13
5.1	Design and function	13
5.2	Product overview	13
5.3	Wind	13
5.4	Virtual temperature	15
5.5	Air pressure	15
5.6	Heating	15
5.6.1	Heating mode	15
5.6.2	Heating capacity	16
5.6.3	Heater switch under voltage	16
5.6.4	Heater boost	16
6	Transport, storage, and unpacking	17
6.1	Unpacking	17

6.2	Storage	17
7	Installation	18
7.1	Mechanical installation	18
7.1.1	Required tools and aids	18
7.1.2	Choosing a site	18
7.1.3	Fastening	19
7.1.4	Aligning to north	19
7.2	Electrical installation	20
7.2.1	Connecting power supply	20
7.2.2	Electrical connections	21
7.2.3	Supply voltage	23
7.2.4	RS485 Interface	23
7.2.5	Analog interface circuits	24
7.2.6	Control line	24
7.2.7	Connecting ISOCON-UMB converter	25
7.2.8	Installing surge protection	25
8	Commissioning for UMB data format	26
8.1	Set up device	26
8.2	Configuration and testing	26
8.2.1	Factory settings	26
8.3	Configuration using UMB binary protocol	27
8.3.1	Configuration using older versions of ConfigTool.NET	27
8.3.2	Specific settings	27
8.3.3	Selecting device	30
8.3.4	General settings	31
8.4	Testing	31
8.5	Example online data request	33
8.5.1	Framing	33
8.5.2	Addressing with Class and Device ID	34
8.5.3	Creating Addresses	34
8.5.4	Requesting binary protocol	34
8.5.5	Status and Error Codes in Binary Protocol	35
8.5.6	CRC Calculation	35
9	Commissioning for SDI-12 data format	36
9.1	Device set-up	36
9.2	Configuration and testing	36
9.3	Command set	36
9.4	Data messages	38
9.5	Additional measurement commands	39
9.6	Message device identification	40
9.7	Message verification	40
9.8	Sensor Configuration Commands for Unit System, Altitude, and Heating Mode	42

10	Commissioning for MODBUS format	43
10.1	Device set-up	43
10.2	Configuration and testing	43
10.3	Addressing	43
10.4	MODBUS functions	44
10.5	Function 0x03 Read Holding Registers	44
10.6	Function 0x06 Write Holding Register, 0x10 Write Multiple Registers	45
10.7	Function 0x04 read input registers	45
10.8	Sensor status	48
11	Maintenance	50
11.1	Maintenance schedule	50
11.2	Updating firmware	50
12	Troubleshooting	51
12.1	Error elimination	51
13	Repair	53
13.1	Customer support	53
14	Notes on disposing of old devices	54
15	Technical data	55
15.1	General technical data	55
15.2	Electrical data	55
15.3	Data transfer	55
15.4	Dimensions and weight	56
15.5	Measuring range and accuracy	57
16	Appendix	59
16.1	Channel list summary	59
16.2	Buffer assignment measurement data	60
16.3	Buffer assignment additional measurement data	61

1 Scope of supply

The following items are included with delivery:

- Ultrasonic wind sensor
- Connection plan

2 Order numbers and variant code

2.1 Product variants

Variant	Order number
Ventus-UMB (metal)	8371.UMT
Ventus-X-UMB (metal)	8371.UMTX
V200A-UMB (plastics)	8371.UA01

2.2 Accessories

Item	Order number
Power supply unit	Phoenix contact TRIO-PS/1AC/24DC/10
ISOCON-UMB	8160.UISO
Surge protection	8379.USP-V
Connector	8371.UST1 or Amphenol C091 31D008 101 2
Connection cable 15 m	8371.UK015

3 About this manual

3.1 Other applicable documents and software

The following documents contain further information on installation, maintenance and calibration:

- User Manual Ultrasonic Wind Sensors
- Operating Manual UMB ISO Converter ISOCON
- Operating instructions surge protection

The following documents and software can be downloaded at www.lufft.com:

- ConfigTool.NET
- UMB protocol description
- Firmware

i The devices can be operated with various protocols, e.g. UMB Binary and UMB-ASCII 2.0. Further information on the protocols and the full description of the UMB channels, or the ASCII, NMEA, SDI-12 and Modbus protocol can be found in the User Manual Ultrasonic Wind Sensors.

3.2 General signs and symbols

The signs and symbols used in the operational manual have the following meaning:

Practical tip

i This symbol indicates important and useful information.

Action

- ✓ Prerequisite that must be met before performing an action.
- ▶ Step 1
 - ⇒ Intermediate result of an action
- ▶ Step 2
 - ⇒ Result of a completed action

List

- List item, 1st level
 - List item, 2nd level

3.3 Explanation of warnings

To avoid personal injury and material damage, you must observe the safety information and warnings in the operating manual. The warnings use the following danger levels:

WARNING

WARNING

This indicates a potentially hazardous situation. If the hazardous situation is not avoided, it may result in death or serious injuries.

CAUTION

CAUTION

This indicates a potentially hazardous situation. If the hazardous situation is not avoided, it may result in moderately serious or minor injuries.

NOTICE

NOTE

This indicates a situation from which damage may arise. If the situation is not avoided, products may be damaged.

4 General safety instructions

4.1 Intended use

The ultrasonic wind sensor is used to determine wind direction and wind speed, and calculate virtual temperature.

Ventus-X with an additional integrated heating is particularly suitable for winter operation.

4.2 Potential misuse

Any use of the product that does not comply with the intended use, be this intentional or negligent, is forbidden by the manufacturer.

- ▶ Use the product only as described in the operational manual.

4.3 Personnel qualification

The equipment described in this manual must be installed, operated, maintained and repaired by qualified personnel only.

- ▶ Obtain training from OTT HydroMet if necessary.

4.4 Operator obligations

The installer is responsible for observing the safety regulations. Unqualified personnel working on the product can cause risks that could lead to serious injury.

- ▶ Have all activities carried out by qualified personnel.
- ▶ Ensure that everybody who works on or with the product has read and understood the operational manual.
- ▶ Ensure that safety information is observed.
- ▶ File the operational manual together with the documentation of the entire system and ensure that it is accessible at all times.
- ▶ The operational manual is part of the product, forward the operational manual together with the product.

4.5 Personnel obligations

To avoid equipment damage and injury when handling the product, personnel are obliged to the following:

- ▶ Read the operational manual carefully before using the product for the first time.
- ▶ Pay attention to all safety information and warnings.
- ▶ If you do not understand the information and procedure explanations in this manual, stop the action and contact the service provider for assistance.
- ▶ Wear the necessary personal protective equipment.

4.6 Correct handling

If the product is not installed, used and maintained correctly, there is a risk of injury. The manufacturer does not accept any liability for personal injury or material damage resulting from incorrect handling.

- ▶ Install and operate the product under the technical conditions described in the operational manual.
- ▶ Do not change or convert the product in any way.
- ▶ Do not perform any repairs yourself.
- ▶ Get OTT HydroMet to examine and repair any defects.
- ▶ Ensure that the product is correctly disposed of. Do not dispose of it in household waste.

4.7 Health hazards

4.7.1 Risk of electrical shock

Live parts can cause electric shocks in the event of contact.

- ▶ Never take measurements on live electrical parts.
- ▶ Never touch live electrical parts.

4.8 Working outdoor

4.8.1 Installation and maintenance at great heights

It is advised to mount the product in a certain height. Therefore, there is a risk of falling down.

- ▶ Observe and follow the local safety regulations.
- ▶ Use suitable safety equipment.
- ▶ Inspect the safety equipment before use.
- ▶ Secure the person mounting or maintaining the device against falling down.
- ▶ Secure the device against falling down.

4.8.2 Using long cables

Long cables are required to mount the product at great heights. Therefore, there is a risk of strangulation.

- ▶ Use long cables properly.
- ▶ Observe manufacturer's instructions.
- ▶ Observe safety regulations.

4.8.3 Working at roadside

The device can be installed on a mast at the roadside. Special safety regulations apply to prevent accidents and injuries.

- ▶ Observe the safety regulations for working at the roadside and in the vicinity of the road carriageway.

4.9 Certification

4.9.1 Europe, USA and Canada

CE (EU)

The device complies with the essential requirements of EMC Directive 2014/30/EU.

FCC (US)

FCC Part 15, Class "B" Limits

The device complies with Part 15 of the FCC Rules. Operation is subject to the following conditions:

- The equipment may not cause harmful interference.
- The equipment must accept any interference received, including interference that may cause undesired operation.

IC (CN)

Canadian Radio Interference-Causing Equipment Regulation, ICES-003, Class B

This Class B digital apparatus meets all requirements of the Canadian Interference-Causing Equipment Regulations.

Canada ICES-003 (B) / NMB-003 (B)

4.9.2 Safety

IEC 61010-1:2010

EN 61010-1:2010

UL 61010-1:2012-05

CAN/CSA-C22.2 No. 61010-1:2012-05

5 Product description

5.1 Design and function

The ultrasonic wind sensor is used to measure and report wind direction, wind speed and calculate virtual temperature.

Depending on the model, the device has a metal or plastic housing and an additional heating for winter operation.

The equipment is connected by way of an 8 pole screw connector and associated connection cable (length 15 m). The measured values are requested over the RS485 interface, half- or full-duplex in accordance with UMB protocol. In addition the device provides an analog output of 2 adjustable channels with 4 - 20 mA, 0 - 10 V or as frequency 2 - 2000 Hz (only possible with channel 1). During commissioning, configuration and measurement polling takes place using the ConfigTool.NET software.

5.2 Product overview

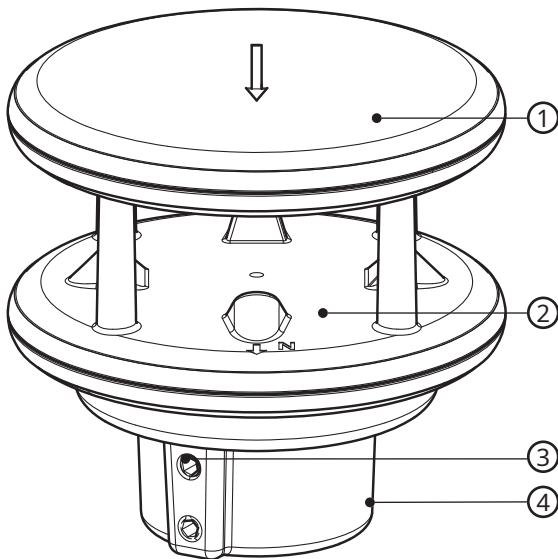

- 1 Reflector
- 2 Measuring section

- 3 Nuts
- 4 Mast mounting connector

5.3 Wind

The measurement principle implemented for the wind sensor is based on the measurement of the time of flight of ultrasonic pulses in air.

The measurement setup includes two measurement sections, arranged at an angle of 90°, with two ultrasonic transceivers each. The measurement sections are activated in turn and the time of flight of the ultrasonic pulses between the respective transmitter and receiver is measured. Within one measurement cycle each of the ultrasonic heads will work once as transmitter and once as receiver.

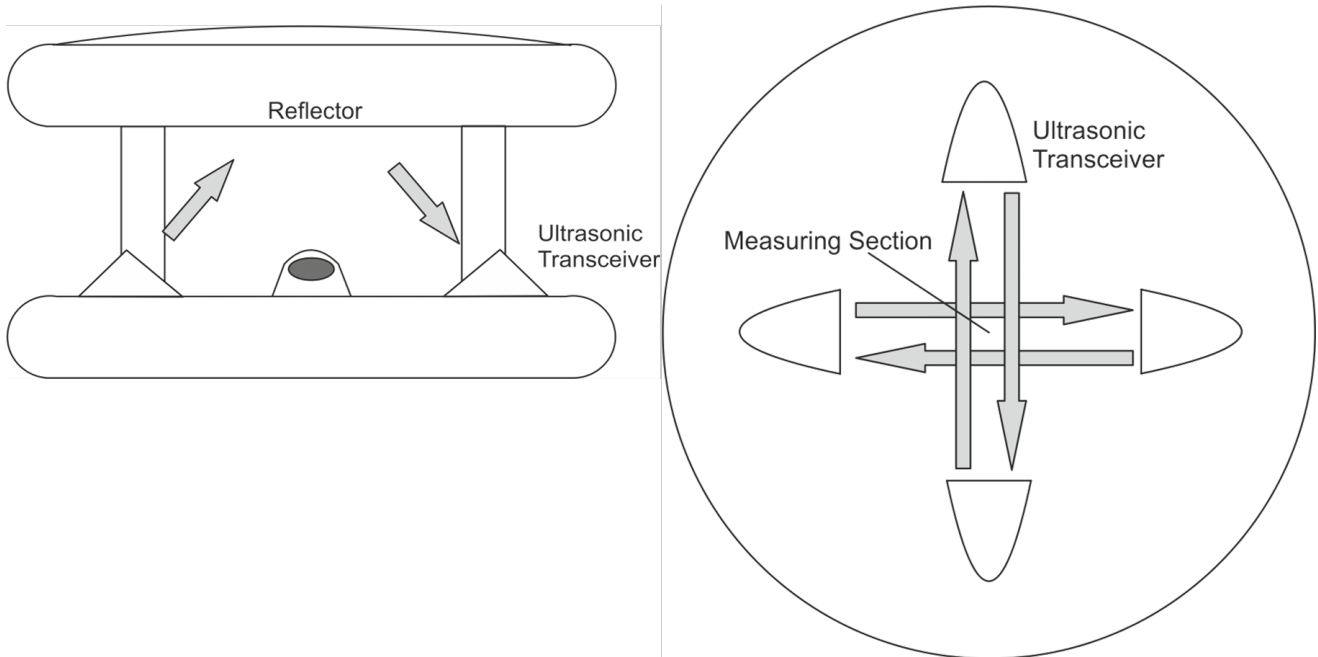

Measurement sections

When measuring in still air all times of flight of one cycle will be equal on average.

If however an air flow is passing through the sensor, the ultrasonic pulse packet moving in the direction of the air flow will be accelerated, while the packet moving in opposite direction to the air flow will be decelerated. That means, the time of flight in the direction of wind will be shorter, while that in direction opposite to the wind direction will be longer.

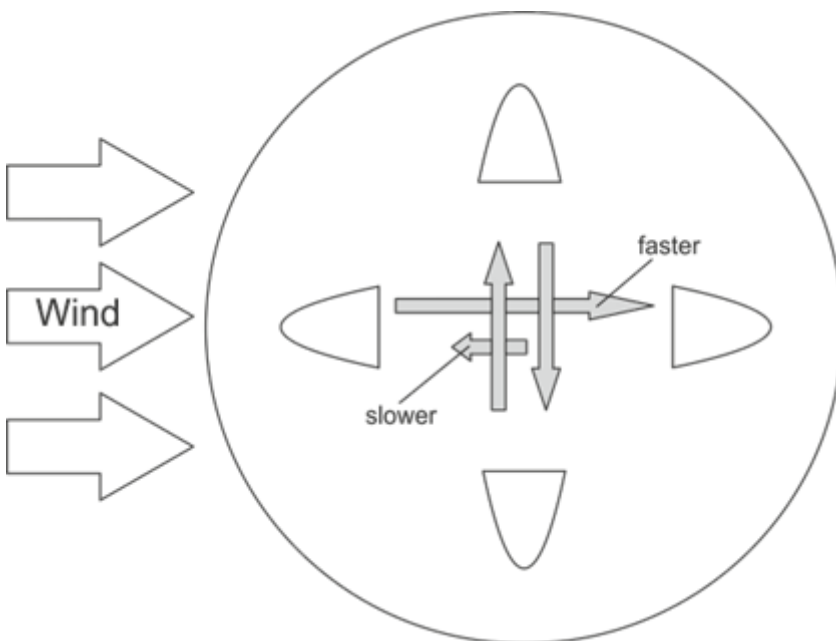

Influence of wind on time of flight

The orthogonal arrangement of the measurement sections allows to evaluate the x and y components (resp. north-south and east-west components) of the air flow. Basically the sonic velocity, and with it the time of flight of the ultrasonic pulse packets, will be influenced by air temperature and air humidity. The alternating measurement (north->south / south->north, west->east / east->west) compensates this influence.

The differences of the time of flight are averaged over a number of measurements, then the wind speed and wind direction is evaluated from the average.

The design of the sensor head protects, to a large extent, the measurement sections against rain and snow. The heating of the sensor prevents icing of the ultrasonic transceivers.

The aerodynamic design of the sensor head minimizes influences on the wind flow. Remaining deviations are evaluated during device calibration so that they are compensated during the calculation of wind speed and wind direction.

5.4 Virtual temperature

Due to the physical relationship between the velocity of propagation of sound and the air temperature, the approximate ambient temperature can be determined with the aid of ultrasound sensors.

5.5 Air pressure

The air pressure is measured by an integrated air pressure sensor.

Air density

Air density is calculated from the measured air pressure, virtual temperature and relative humidity. The wind sensor doesn't measure relative humidity. Therefore a constant value, which can be adjusted through ConfigTool.NET, is applied. The factory setting is 75%.

5.6 Heating

For winter operation Ventus has got 2 heating elements (one element only on plastic version) to keep the sensor free of snow and ice. One element is in the cover (metal version only) and the other is built into the ultrasonic sensors.

To reduce the maximum operating current of the device, upper and lower heating can be switched alternately.

Separate measurement channels are available for the surveillance of the temperatures of upper and lower heater.

By default the heating is set in automatic mode and full capacity. This is the recommended heating mode of the sensor.

For configuration of the heating settings, see Heating settings [▶ 27].

5.6.1 Heating mode

The heating of the device can be operated in 4 different modes:

Mode	Performance
off	Heating always off
auto	Automatic heating control ¹ The heating switches on when the housing temperature falls below +15 °C (adjustable between 2 °C and 20 °C) and switches off at a housing temperature of > +20 °C (set temperature +5 °C) (metal) The heating switches on when the housing temperature falls below +50 °C (adjustable between 2 °C and 70 °C) and switches off at a housing temperature of > +55 °C (set temperature +5 °C) (plastics)

Mode	Performance
testmode	The switch-on temperature is adjusted to +40 °C; in this condition the heating switches on at room temperature (for test purposes only)
ctrl high	Heating control is disabled when the control line is at the "high" level, else automatic
ctrl low	Heating control is disabled when the control line is at the "low" level, else automatic

¹Factory default

5.6.2 Heating capacity

The heating capacity can be set in accordance with the following modes:

Mode	Performance
full	Full heating capacity (ca. 240 W) ^{1, 2}
alternating	Alternating heating: Cover plate alternating to base plate (ca. 100 W or 150 W alternating) The next level of heating switches in if the pre-set temperature for the respective level is not reached within 4 minutes. In this mode you only need a power supply with 140 W

¹Factory default

²The above mentioned heating capacity is calculated for an operating voltage of 24 V. With 12 V supply voltage only 25 % of this capacity is available.

5.6.3 Heater switch under voltage

If the *heater turn off on over / under voltage* is activated, the heating will be automatically switched off, if the supply voltage is outside of the surveillance window.

The lower threshold is ~20 V, the upper threshold is ~28 V.

5.6.4 Heater boost

Under conditions of wet snow at temperatures around 0° C together with strong winds it may happen that the ultrasonic measurement volume becomes blocked by slush, causing the status of the wind measurement to change to error.

If the heater boost function mode is activated it will, in case of an error, temporarily increase the heater setpoint temperature to speed up the melting of the slush.

6 Transport, storage, and unpacking

6.1 Unpacking

- ▶ Carefully remove the product from the packaging.
- ▶ Check that the delivery is complete and undamaged.
- ▶ If you find any damage or if the delivery is incomplete, then immediately contact your supplier or manufacturer.
- ▶ Keep the original packaging for any further transportation.

6.2 Storage

- ▶ Store within specified temperature ranges.
- ▶ Store in dry area.
- ▶ Store in original box where possible.

7 Installation

7.1 Mechanical installation

7.1.1 Required tools and aids

The following tools and aids are required:

- hexagon socket 4.0
- compass

7.1.2 Choosing a site



Risk of injury due to improper installation!

If the mast or the device is installed improperly, damage to the device and injury to people may result.

- ▶ Ensure that the mast stands on a stable surface.
- ▶ Ensure that the mast is sized and anchored appropriately.
- ▶ Ensure that the mast is earthed in accordance with the regulations.
- ▶ Use only approved and tested appliances (conductors, risers etc.) to install the device on the mast.

- ▶ Ensure the following at the site:
 - Free access to the equipment for maintenance works
 - Reliable power supply for permanent operation
 - Good network coverage when transmitting over a mobile communications network

7.1.2.1 Installing device

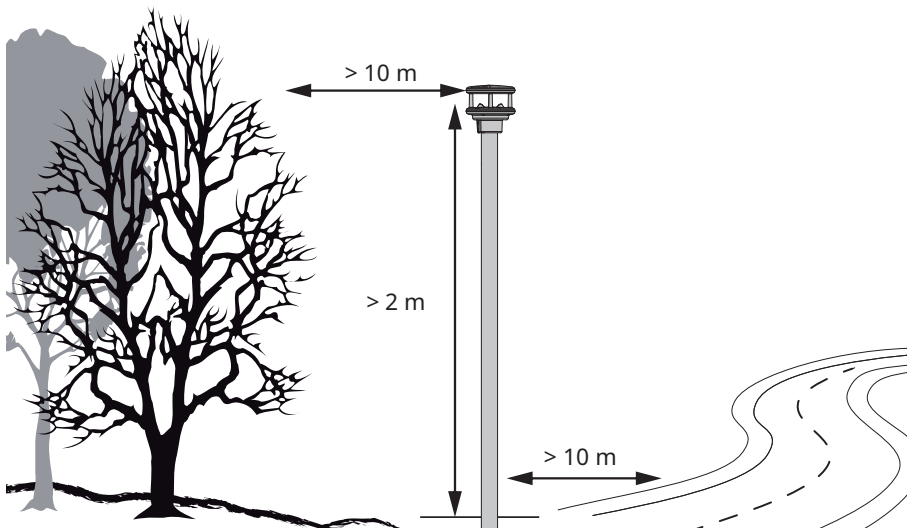

- ▶ Install the device on top of the mast at least 2 m above the ground.
- ▶ Ensure there is free field around the device.
- ▶ Keep a distance of at least 10 m to the device from shadowing objects, e.g. trees and buildings.

- i** Buildings, bridges, embankments and trees may corrupt the wind measurement. Passing traffic may cause gusts which may influence the wind measurement.

7.1.3 Fastening

The mounting bracket is designed to be installed on top of a mast with a diameter of 50 mm (2").

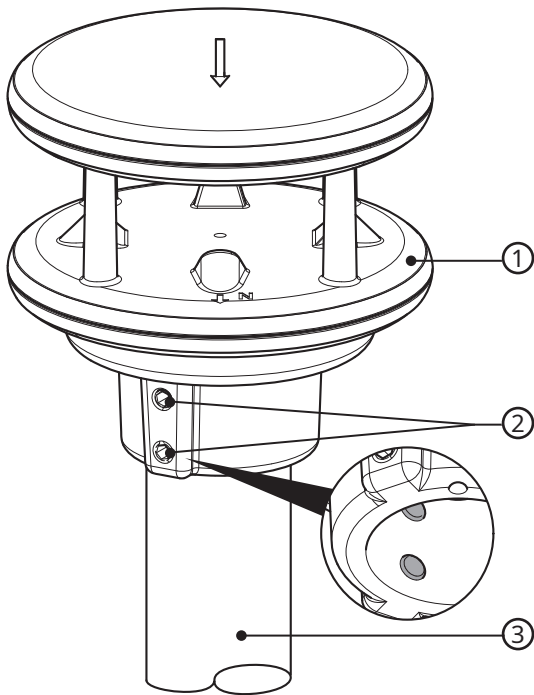

- 1 Ventus
2 Nut

- 3 Mast

- ▶ Loosen the nuts.
- ▶ Push the device onto the top of the mast from above.
- ▶ Align the device to the north.
- ▶ Tighten both nuts evenly and secure with locking varnish.

7.1.4 Aligning to north

In order for the wind direction to be displayed correctly, the device must be aligned to the north. The device has a number of directional arrows and a north drill hole for this purpose.

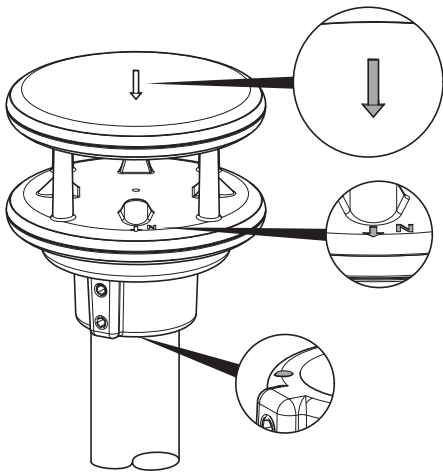

- ▶ If the device is already installed, loosen both nuts evenly until the device can be turned easily.
- ▶ Using the compass, identify the north and fix a point of reference on the horizon.
- ▶ Position the device in such a way that the south and north sensors are aligned with the fixed point of reference in the north.

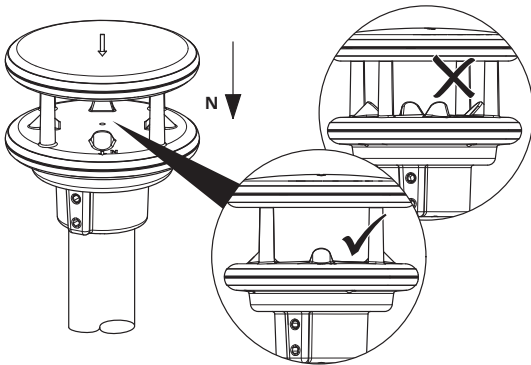

- ▶ Tighten both nuts evenly.

i The magnetic North Pole displayed by the compass differs from the Geographic North Pole. When aligning the device, the declination (variation) at the location must be taken into account. Depending on the location, the deviation can be more than 15°, for example in North America. In Central Europe the variation is less than 3° and can be neglected.

7.2 Electrical installation

7.2.1 Connecting power supply

The metal variants (Ventus-UMB and Ventus-X-UMB) are earthed through the screws with the earthed mast. For the device the ground of the power supply unit is not attached to the earthing connection in the control panel.

For the plastic device (V200A-UMB), the sensor supply cable is connected to the power supply in the control panel. The cable shielding must be attached to the earthing connection in the control panel.

It is recommended to shorten the connecting cable to the minimum length necessary to minimize the voltage drop on the cable. Thus the maximum heating power is enabled.

Example

- Cable length 15 m: maximum of 150 W heating power available on the device
- Cable length > 15 m: must be adapted to a larger cable cross-section in the supply wires (2.5 - 4 mm² corresponds to approx. 20 - 50 m cable length)

7.2.2 Electrical connections



Electric shock due to incorrectly connected device!

If the device is not connected correctly, it may be permanently damaged and an electric shock may result.

- ▶ Ensure that the device is connected correctly.
- ▶ For Ventus: Ensure that the cable shielding is not connected to earth in the control cabinet.
- ▶ For V200A: Ensure that the cable shielding is connected to earth in the control cabinet.

There is an 8 pole screw connector on the underside of the device. This serves to connect the supply voltage and the interfaces via the connection cable.

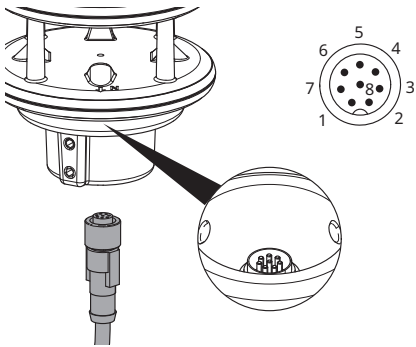

Pin assignment full-duplex

Number	Signal designator	Color	Assignment
1	Y	pink	Serial interface RXD-
2	B	yellow	Serial interface TXD-
3	–	red	Control connection
4	Z	grey	Serial interface RXD+
5	A	green	Serial interface TXD+
6	–	blue	Analog ground
7	–	white	Supply voltage -
8	–	brown	Supply voltage +

Pin assignment half-duplex / analog interface

Number	Signal designator	Color	Assignment
1	–	pink	Analog interface A
2	B	yellow	Serial interface RXD/TXD-
3	–	red	Control connection

Number	Signal designator	Color	Assignment
4	–	grey	Analog interface B
5	A	green	Serial interface RXD/TXD+
6	–	blue	Analog ground
7	–	white	Supply voltage -
8	–	brown	Supply voltage +

Pin assignment SDI-12 interface

Number	Color	Assignment
1	pink	–
2	yellow	SDI-12 Data
3	red	SDI-12 activation
4	grey	–
5	green	–
6	blue	SDI-12 GND and SDI-12 activation
7	white	Supply voltage -
8	brown	Supply voltage +

7.2.2.1 Connecting devices in SDI-12 mode

Two options for the power supply are available, when connecting the device to a SDI-12 logger:

- ▶ Connect the SDI-12 12 V line.
- ▶ Alternatively, connect a separate power source, isolated from the logger. (NOTE: OTT HydroMet recommends the Phoenix contact TRIO-PS/1AC/24DC/10)

Power supply by the SDI-12 bus

Number	Color	Assignment
1	pink	–
2	yellow	SDI-12 Data
3	red	–
4	grey	–
5	green	–
6	blue	–
7	white	SDI-12 GND
8	brown	SDI-12 12 V

Pin assignment: Supply voltage and SDI-12

When using this connection option, the internal isolation of the sensor power supply will be bypassed.

The resistor must be mounted at the end of the cable which it is connected to by the logger. Otherwise the voltage drop over the cable may cause potential differences which prohibit communication.

The specification of SDI-12 requires only 0.5 A max. load of for the 12 V line. This is insufficient for the sensor heating.

- ▶ In case of power supply through the SDI-12 bus, deactivate the heating in the Ventus configuration.

If heating is required, power supply through a separate source with sufficient performance has to be chosen:

Number	Color	Assignment
1	pink	–
2	yellow	SDI-12 Data
3	red	–
4	grey	–
5	green	–
6	blue	SDI-12 GND
7	white	GND (separate power supply)
8	brown	+VCC (separate power supply)

Pin assignment: Supply voltage and SDI-12

7.2.3 Supply voltage

The supply voltage is 24 V DC \pm 10 %. The power supply unit used must be approved for operation with equipment of protection class III (SELV). Limitations apply in case of supply voltages of 12 V DC \pm 10 %

7.2.3.1 Limitations in 12 V mode

If the heating is operated on 12 V DC, the functional restrictions in winter operation has to be kept in mind. A heating voltage of 24 V DC is recommended to guarantee full heating duty.

7.2.4 RS485 Interface

The device has an electrically isolated, half- or full-duplex, two- or four-wire RS485 interface for configuration, measurement polling and the firmware update.

7.2.4.1 Full-duplex

The following operating restrictions exist for the full-duplex operation setting:

- autonomous telegram transmission is possible
- transmission of values via current output is not possible
- heating control via control pin is possible
- triggering of NMEA telegram transmission over control pin is possible
- SDI-12 mode is not possible
- firmware update is not possible

7.2.4.2 Half-duplex

The following operating restrictions exist for the half-duplex¹ operation setting:

- no autonomous telegram transmission is possible
- transmission of values via current output is possible
- heating control via control pin is possible
- triggering of NMEA telegram transmission over control pin is not possible

- SDI-12 mode is possible
- firmware update is possible

¹Factory default

7.2.5 Analog interface circuits

Two analog interface circuits are provided for analog data transmission. The circuits are updated every 250 ms.

The channels to be transmitted by way of the two interfaces can be adjusted in the UMB-Config-Tool. Default values: Channel 400 (current wind speed in m/s (A)), Channel 500 (current wind direction (B)).

- i** Starting with firmware version v36 analog outputs may be operated in parallel to all serial communication protocols, except of SDI-12, Clipper and full-duplex operation. Earlier firmware only permits UMB binary protocol in half-duplex operation.

The interfaces can be configured for the following outputs:

Interface A

- current output: 0 - 20 mA (default: 4 - 20 mA)
- voltage output: 0 - 10 V or 2 - 10 V
- frequency output: 2 - 2000 Hz (with adjustable voltage level up to 10 V)

Interface B

- current output: 0 - 20 mA (default: 4 - 20 mA)
- voltage output: 0 - 10 V or 2 - 10 V

The scaling of the outputs is adjustable. The maximum load on the current output is 300 Ohm.

7.2.6 Control line

The respective function can be adjusted using the UMB-Config-Tool. The control line can be used either to control heating in half or full duplex operation or to control telegram transmission in full duplex mode. In this case control is possible by means of a volt-free switching contact.

Control line at "high" when control and analog ground are not connected.

Control line at "low" when control and analog ground are short-circuited.

For activation of the SDI-12 mode the control line is to be set to "low", i.e. control input and analog ground are to be connected.

7.2.6.1 Control line disabled

The control line level has no effect.

7.2.6.2 Heating control

Heating is disabled, when control line is at "high" or "low" level, otherwise automatic.

7.2.6.3 Control of telegram transmission in NMEA protocol

Telegram transmission triggered on rising or falling edge of control voltage.

Telegram transmission while control voltage is "high" or "low".

7.2.7 Connecting ISOCON-UMB converter

The ISOCON-UMB communication module converts RS485 into RS232.

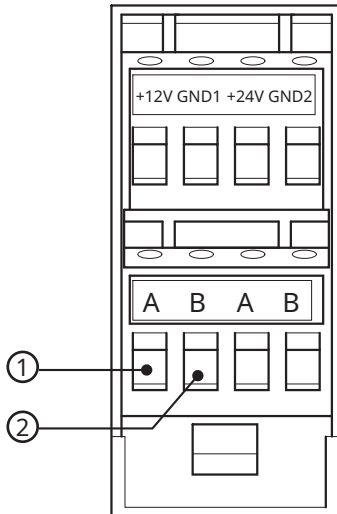

1 Green: RS485 interface A

2 Yellow: RS485 interface B

- ▶ Connect the green and yellow wires to the ISOCON-UMB converter.
- ▶ Connect the red and blue wires direct to the power supply unit, not to the ISOCON-UMB converter.
- ▶ Refer to the operating manual UMB ISO converter ISOCON.

7.2.8 Installing surge protection

The surge protection serves to protect the device against voltage spikes.

- ▶ Install the surge protection between the device and ISOCON-UMB converter.
- ▶ Refer the operating instructions of the surge protection.

8 Commissioning for UMB data format

i The devices can be operated with various protocols, e.g. UMB Binary and UMB-ASCII 2.0. Further information on the protocols and the full description of the UMB channels, or the ASCII, NMEA, SDI-12 and Modbus protocol can be found in the User Manual Ultrasonic Wind Sensors.

8.1 Set up device

After the equipment has been installed and connected correctly, the device begins autonomously to take measurements. No protective cover needs to be removed from the device.

The following is required for configuration and testing purposes:

- Windows® PC with serial interface
- ConfigTool.NET software
- Interface cable: RS485 – USB interface adapter

Proceed as follows for commissioning:

- ▶ Check for correct equipment operation on site by carrying out a measurement request with the aid of the ConfigTool.NET software.
- ▶ To ensure a correct wind measurement, align the device to the north.
- ▶ If several devices are operated on a UMB network, assign a unique device ID to each sensor.

8.2 Configuration and testing

For configuration and testing OTT HydroMet Fellbach GmbH provides the proprietary software ConfigTool.NET. ConfigTool.NET can also be used to update the firmware of the device.

- ▶ Download the ConfigTool.NET software: www.lufft.com/resources/
- ▶ Install the software on the computer.
- ▶ Get familiar with the software in general.
- ▶ Ensure to always use the latest version of ConfigTool.NET.
- ▶ During configuration and testing, disconnect other devices that poll the UMB-Bus, e.g. modem or LCOM.
- ▶ Ensure that the connection settings of ConfigTool.NET are conform to the settings of the device.

i The operation of the ConfigTool.NET is described in detail in the help function of the Windows® PC software. For this reason only the menus and functions specific to the device are described below.

8.2.1 Factory settings

The device is delivered with the following settings:

Specification	Value
Class ID	8
Device ID	1
Baudrate	19200
RS485 protocol	Binary
Data format	8N1

8.3 Configuration using UMB binary protocol

8.3.1 Configuration using older versions of ConfigTool.NET

When using older versions of ConfigTool.NET or other tools the communication can be opened by the following procedure:

- ▶ Connect the PC to the device through a RS485 converter.
- ▶ Open the page *Device Settings*.
- ▶ Alternatively, start the measurement with at least one channel and with 1 second polling rate.
- ▶ Restart the device (power off / on).
- ⇒ The device establishes the connection (green indicator, "Connected") within a few seconds.
- ⇒ When using the alternative method valid measurement values will be indicated within a few seconds. The ConfigTool.NET measurement can then be stopped.
- ⇒ The interface is now open for configuration.

8.3.2 Specific settings

8.3.2.1 Heating settings

Heating Parameters	
Setpoint temperature [°C]	15
Heater mode	auto
Capacity	full
Disable if overvoltage	yes
Disable if undervoltage	no
Wind Heater Boost Time	120
Setpoint Temp. for Wind Heater Boost	35
Min. error time for Heater Boost	5
Max. Temp. for Heater Boost	10

Parameter	Description
Setpoint temperature	Temperature to which the device is heated Default setting: 15 °C
Heater mode	The device can be configured for heating in different operating modes. Select <i>Auto</i> in normal operating mode. off: heating is off auto: automated control to setpoint temperature testmode: the device is heated to test setpoint temperature ctrl high: heating off if control line on high ctrl low: heating off if control line on low otherwise: automatic control default: auto
Capacity	full: full heating power alternating: upper plate and lower plate alternatingly default: full
Disable if overvoltage	the heating is disabled if overvoltage (28 V) is detected default: yes
Disable if undervoltage	the heating is disabled if undervoltage (20 V) is detected default: no

Parameter	Description
Wind heater boost time	Length of heater boost in seconds (0 to 900 sec) default: 300 sec
Setpoint temperature for wind heater boost	Setpoint temperature for the heating boost in °C, max. 40 °C default: 40 °C
Min. error time for heater boost	Minimum time of wind measurement error status in seconds, for triggering the heater boost, max. 900 sec Minimum error time 0 deactivates the heater boost default: 0 sec
Max. temperature for heater boost	Maximum environmental temperature in °C for triggering the heater boost, max. 20 °C default: 10 °C

8.3.2.2 Wind settings

Wind Parameters	
Analog: delayed error output	0
Min. speed	0.1
Counts of measurements	60
Direction offset	0
Measurement rate [s]	10
Hold Wind Direction below Min. speed	enabled

Parameter	Description
Analog: delayed error output	Continuous wind measurement error duration in seconds, until the analog outputs are set to error indication value. default: 0 sec
Min. speed	Starting speed of the wind sensor in m/s default: 0.1 m/s
Counts of measurements	Number of measured values used for determining the statistical values of average, minimum value and maximum value default: 60
Direction offset	Correction of the wind direction It is possible to have an offset added to the measured wind direction, in order to convert e.g. 0° (North) into 180° (South) default: 0°
Measurement rate	Update interval, adjustable in 250 m/s, 1 to 10 sec default: 10 sec
Hold Wind Direction below Min. speed	Select which wind direction to be shown if the wind speed is below the starting speed of the wind sensor. disabled: output 0.0 enabled: hold last valid wind direction until the wind speed again exceeds the starting speed of the wind sensor. default: disabled

8.3.2.3 Pressure settings

Pressure Parameters	
Pressure offset	0
Counts of measurements	10
Relative air humidity [%]	75

Parameter	Description
Pressure offset	Absolute offset (for on-site adjustment) on the measured value
Counts of measurements	Number of measured values used for determining the statistical values of average, minimum value and maximum value default: 10
Relative air humidity [%]	Assumed average value of relative humidity, used for calculation of air density default: 75 %

8.3.2.4 Analog output settings

Analog Output Parameters	
1 enable	current
1 Channel number	400
1 Min. current [mA]	4
1 Max. current [mA]	20
1 Min. value	0
1 Max. value	90
1 Error current [mA]	2
2 enable	current
2 Channel number	500
2 Min. current [mA]	4
2 Max. current [mA]	20
2 Min. value	0
2 Max. value	359.9
2 Error current [mA]	2
1 Voltage (if used as frequency output)	5

The following parameters are available for both analog outputs:

Parameter	Description
Enable	off: the output is not used current: the output is used as a current output voltage: the output is used as a voltage output frequency: the output is used as a frequency output (only output 1) default: off
Channel number	Number of the measurement channel whose values shall appear default: 400 (output 1), 500 (output 2)
Min. and max. current / voltage / frequency	Analog limitations of the analog output 0 - 20 mA default: 4 - 20 mA 0 - 10 V 2 - 2000 Hz
Min. and max. value	Digital limitations of the analog output default: 0 - 90 m/s

Parameter	Description
Error current	Current that is delivered in case on an error default: 2 mA
Additional parameter for analog output 1	
Voltage (if used as frequency output)	Voltage that represents the high states of the frequency signal 0 - 10 V default: 5 V

Example

The wind speed of 0 - 90 m/s is generated as 4 - 20 mA.

A speed of 20 m/s is therefore generated as $(20 \text{ mA} - 4 \text{ mA}) / (90 \text{ m/s} - 0 \text{ m/s}) * 20 \text{ m/s} + 4 \text{ mA} = 7.56 \text{ mA}$

8.3.3 Selecting device

- ▶ Select an existing workspace or create a new one.
- ▶ Click the button  to add a new device to the workspace.

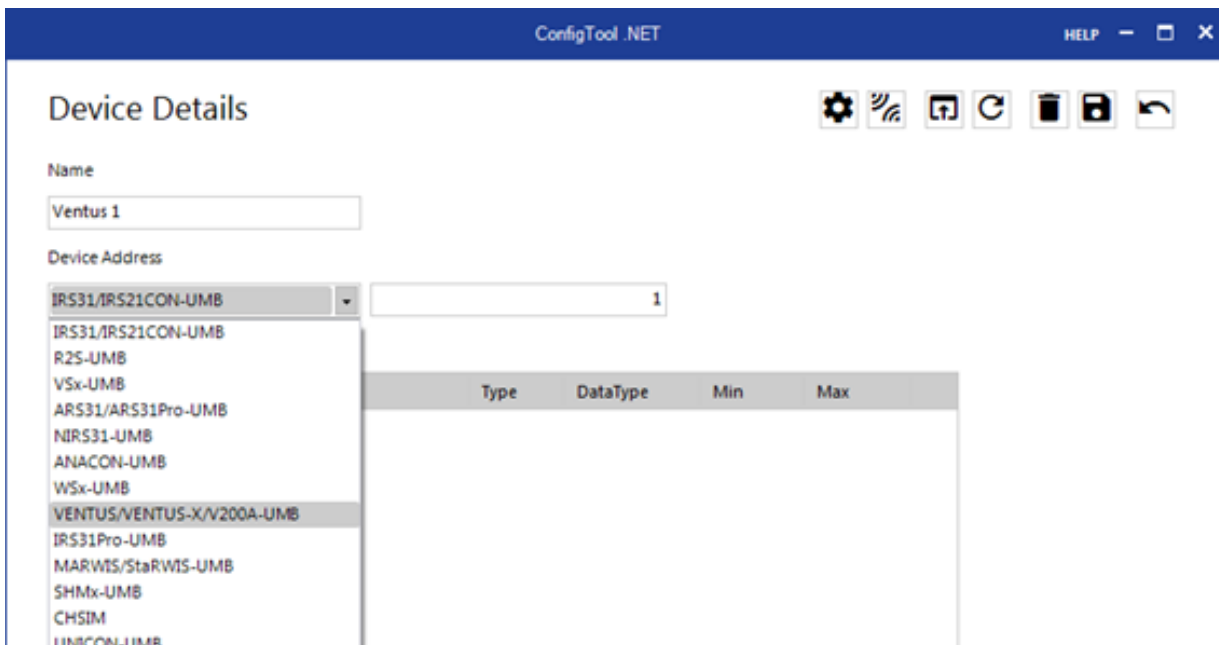

⇒ The wind sensor appears in the selection menu as *VENTUS/VENTUS-X/V200A-UMB* (Class ID 8).

- ▶ Enter a *Name* for the new device and adjust the *Device ID* if necessary.
- ▶ Confirm with **OK**.

8.3.4 General settings

General device description	
Running number	176
Date of production	1116
Project number	901
BOM rev.	10
Schematic rev.	5
HW rev.	5
SW rev.	31
Configuration rev.	17
Device rev.	29
Calibration rev.	13
Device type	0
Device identification	
Class-ID	8
Device-ID	1
Device name	VENTUS-V200A-UMB
Device description	ultrasonic metal wind sensor VENTUS-...
Device parameters	
Baudrate	19200 Bd
Protocol	UMB BINARY
Protocol timeout [min]	10

Parameter	Description
Device-ID	Factory setting: 1 Assign the IDs for the devices in ascending order.
Device description	To differentiate the devices enter a description, e.g. the location.
Baudrate	Transmission speed of the RS485 interface Factory setting: 19200 DO NOT change for operation with ISOCON-UMB.
Protocol	Communication protocol of the device: UMB-Binary, UMB-ASCII, NMEA, SDI-12, MODBUS-RTU, MODBUS-ASCII
Timeout for protocol change	In the event of a temporary changeover of the communication protocol, the system switches back to the configured protocol after this time (in minutes).

- i If the baudrate is changed, after saving the configuration on the device, the device communicates at the new baudrate. When operating the device in a UMB network with ISOCON-UMB, this baudrate must not be changed; otherwise the device is no longer addressable and can no longer be configured.

8.4 Testing

The functions of the device can be tested with the ConfigTool.NET software by polling various channels.

► Click on the desired channel.

Device Details

Name: Ventus 1

Device Address: VENTUS/VENTUS-X/V200A-UMB 1

Channels

Number	Name	Type	DataType	Min	Max	
<input checked="" type="checkbox"/>	100	virtual temperature	Cur [°C]	Float32	-50	70
<input type="checkbox"/>	120	virtual temperature	Min [°C]	Float32	-50	70
<input type="checkbox"/>	140	virtual temperature	Max [°C]	Float32	-50	70
<input checked="" type="checkbox"/>	160	virtual temperature	Avg [°C]	Float32	-50	70
<input type="checkbox"/>	105	virtual temperature	Cur [°F]	Float32	-58	158
<input type="checkbox"/>	125	virtual temperature	Min [°F]	Float32	-58	158
<input type="checkbox"/>	145	virtual temperature	Max [°F]	Float32	-58	158
<input type="checkbox"/>	165	virtual temperature	Avg [°F]	Float32	-58	158
<input type="checkbox"/>	112	heater temp. top	Cur [°C]	Float32	-50	150
<input type="checkbox"/>	113	heater temp. bottom	Cur [°C]	Float32	-50	150
<input type="checkbox"/>	117	heater temp. top	Cur [°F]	Float32	-58	302
<input type="checkbox"/>	118	heater temp. bottom	Cur [°F]	Float32	-58	302
<input type="checkbox"/>	300	abs. air pressure	Cur [hPa]	Float32	300	1200
<input type="checkbox"/>	320	abs. air pressure	Min [hPa]	Float32	300	1200
<input type="checkbox"/>	340	abs. air pressure	Max [hPa]	Float32	300	1200
<input type="checkbox"/>	360	abs. air pressure	Avg [hPa]	Float32	300	1200
<input type="checkbox"/>	305	rel. air pressure	Cur [hPa]	Float32	300	1200
<input type="checkbox"/>	325	rel. air pressure	Min [hPa]	Float32	300	1200
<input type="checkbox"/>	345	rel. air pressure	Max [hPa]	Float32	300	1200
<input type="checkbox"/>	365	rel. air pressure	Avg [hPa]	Float32	300	1200
<input checked="" type="checkbox"/>	400	wind speed	Cur [m/s]	Float32	0	90
<input type="checkbox"/>	401	wind speed	Cur [m/s]	Float32	0	90
<input checked="" type="checkbox"/>	420	wind speed	Min [m/s]	Float32	0	90
<input checked="" type="checkbox"/>	440	wind speed	Max [m/s]	Float32	0	90
<input checked="" type="checkbox"/>	460	wind speed	Avg [m/s]	Float32	0	90
<input checked="" type="checkbox"/>	480	wind speed	Vct [m/s]	Float32	0	90
<input type="checkbox"/>	405	wind speed	Cur [km/h]	Float32	0	324
<input type="checkbox"/>	406	wind speed	Cur [km/h]	Float32	0	324
<input type="checkbox"/>	425	wind speed	Min [km/h]	Float32	0	324
<input type="checkbox"/>	445	wind speed	Max [km/h]	Float32	0	324
<input type="checkbox"/>	465	wind speed	Avg [km/h]	Float32	0	324
<input type="checkbox"/>	485	wind speed	Vct [km/h]	Float32	0	324
<input type="checkbox"/>	410	wind speed	Cur [mph]	Float32	0	201
<input type="checkbox"/>	411	wind speed	Cur [mph]	Float32	0	201
<input type="checkbox"/>	430	wind speed	Min [mph]	Float32	0	201
<input type="checkbox"/>	450	wind speed	Max [mph]	Float32	0	201
<input type="checkbox"/>	470	wind speed	Avg [mph]	Float32	0	201
<input type="checkbox"/>	490	wind speed	Vct [mph]	Float32	0	201
<input type="checkbox"/>	415	wind speed	Cur [kts]	Float32	0	175
<input type="checkbox"/>	416	wind speed	Cur [kts]	Float32	0	175
<input type="checkbox"/>	435	wind speed	Min [kts]	Float32	0	175
<input type="checkbox"/>	455	wind speed	Max [kts]	Float32	0	175
<input type="checkbox"/>	475	wind speed	Avg [kts]	Float32	0	175
<input type="checkbox"/>	495	wind speed	Vct [kts]	Float32	0	175
<input checked="" type="checkbox"/>	500	wind direction	Cur [°]	Float32	0	360
<input type="checkbox"/>	501	wind direction	Cur [°]	Float32	0	360
<input type="checkbox"/>	520	wind direction	Min [°]	Float32	0	360
<input type="checkbox"/>	540	wind direction	Max [°]	Float32	0	360
<input type="checkbox"/>	580	wind direction	Vct [°]	Float32	0	360
<input checked="" type="checkbox"/>	805	wind value quality	Cur [%]	Float32	0	100
<input type="checkbox"/>	1048	virtual temperature	Cur [TLS F...]	Sint16	-300	600
<input type="checkbox"/>	1056	wind direction	Vct [TLS F...]	Uint16	0	359
<input type="checkbox"/>	1057	wind speed	Vct [TLS F...]	Uint16	0	600
<input type="checkbox"/>	1064	wind speed	Max [TLS...]	Uint16	0	600
<input type="checkbox"/>	1054	rel. air pressure	Cur [TLS F...]	Uint16	800	1200
<input type="checkbox"/>	4006	supply over voltage	Cur [logic]	Uint8	0	1
<input type="checkbox"/>	4007	supply under voltage	Cur [logic]	Uint8	0	1

Dec COM4

Timestamp	virtual temperature 100 [°C] Cur	virtual temperature 160 [°C] Avg	wind speed 400 [m/s] Cur	wind speed 420 [m/s] Min	wind speed 440 [m/s] Max	wind speed 460 [m/s] Avg	wind speed 480 [m/s] Vct	wind direction 500 [°] Cur	wind value quality 805 [%] Cur
12:22:17	16.529	16.615	0.290	0.107	2.733	0.177	0.168	332.074	100.000
12:22:18	16.529	16.615	0.290	0.107	2.733	0.177	0.168	332.074	100.000
12:22:19	16.529	16.615	0.290	0.107	2.733	0.177	0.168	332.074	100.000
12:22:20	16.529	16.615	0.290	0.107	2.733	0.177	0.168	332.074	100.000
12:22:21	16.529	16.615	0.399	0.000	2.733	0.181	0.160	337.649	100.000
12:22:22	16.529	16.615	0.399	0.000	2.733	0.181	0.160	337.649	100.000
12:22:23	16.529	16.615	0.399	0.000	2.733	0.181	0.160	337.649	100.000
12:22:24	16.529	16.615	0.399	0.000	2.733	0.181	0.160	337.649	100.000
12:22:25	16.529	16.615	0.399	0.000	2.733	0.181	0.160	337.649	100.000
12:22:26	16.473	16.612	0.399	0.000	2.733	0.181	0.160	337.649	100.000
12:22:27	16.473	16.612	0.399	0.000	2.733	0.181	0.160	337.649	100.000
12:22:28	16.473	16.612	0.399	0.000	2.733	0.181	0.160	337.649	100.000
12:22:29	16.473	16.612	0.399	0.000	2.733	0.181	0.160	337.649	100.000
12:22:30	16.473	16.612	0.399	0.000	2.733	0.181	0.160	337.649	100.000
12:22:31	16.473	16.612	0.614	0.000	3.321	0.189	0.150	333.401	100.000
12:22:32	16.473	16.612	0.614	0.000	3.321	0.189	0.150	333.401	100.000
12:22:33	16.473	16.612	0.614	0.000	3.321	0.189	0.150	333.401	100.000
12:22:34	16.473	16.612	0.614	0.000	3.321	0.189	0.150	333.401	100.000

Example of measurement polling

The ConfigTool.NET software is provided for test and configuration purposes only. The tool is not suitable for the permanent acquisition of measurement data. For this purpose the use of professional software is recommended, e.g. Lufft SmartView3.

8.5 Example online data request

Only one example of an online data request is described in this operating manual. Please refer to the current version of the UMB Protocol for all commands and the exact mode of operation of the protocol (available for download at www.lufft.com).

Communication with the sensor takes place in accordance with the master-slave principle, i.e. there may only be ONE requesting unit on a network.

8.5.1 Framing

The data frame is constructed as follows:

1	2	3-4	5-6	7	8	9	10	11 ... (8 + len) optional	9 + len	10 + len 11 + len	12 + len
SOH	<ver>	<to>	<from>	<len>	STX	<cmd>	<verc>	<payload>	ETX	<cs>	EOT

SOH: Control character for the start of a frame (01h); 1 byte

<ver>: Header version number, e.g.: V 1.0 →<ver> = 10h = 16d; 1 byte

<to>: Receiver address; 2 bytes

<from>: Sender address; 2 bytes

<len>: Number of data bytes between STX and ETX; 1 byte

STX: Control character for the start of payload transmission (02h); 1 byte

<cmd>: Command; 1 byte

<verc>: Version number of the command; 1 byte

<payload>: Data bytes; 0 – 210 bytes

ETX: Control character for the end of payload transmission (03h); 1 byte

<cs>: Check sum, 16 bit CRC; 2 bytes

EOT: Control character for the end of the frame (04h); 1 byte

Control characters: SOH (01h), STX (02h), ETX (03h), EOT (04h).

8.5.2 Addressing with Class and Device ID

Addressing takes place by way of a 16 bit address. This breaks down into a Class ID and a Device ID.

Address (2 bytes = 16 bit)					
Bits 15 – 12 (upper 4 bits)		Bits 11 – 8 (middle 4 bits)		Bits 7 – 0 (lower 8 bits)	
Class ID (0 to 15)		Reserve		Device ID (0 – 255)	
0	Broadcast			0	Broadcast
8	Ventus			1 - 255	Available
15	Master or control devices				

ID = 0 is provided as broadcast for classes and devices. Thus it is possible to transmit a broadcast on a specific class. However this only makes sense if there is only one device of this class on the bus; or in the case of a command, e.g. reset.

8.5.3 Creating Addresses

If, for example, you want to address Ventus with the device ID 001, this takes place as follows:

The class ID for the Ventus is 8d = 8h;

the device ID is e.g. 001d = 01h

Putting the class and device IDs together gives the address 8001h (32769d).

8.5.4 Requesting binary protocol

If, for example, a Ventus with the device ID 001 is to be polled from a PC for the current temperature, this takes place as follows:

Sensor:

The class ID for the Ventus is 8 = 8h; the device ID is 001 = 01h

Putting the class and device IDs together gives a target address of 8001h.

PC:

The class ID for the PC (master unit) is 15 = Fh;

the PC ID is e.g. 001d = 01h

Putting the class and device IDs together gives a sender address of F001h.

The length <len> for the online data request command is 4d = 04h;

the command for the online data request is 23h;

the version number of the command is 1.0 = 10h.

The channel number is in <payload>; as can be seen from the channel list in the appendix, the current temperature in °C in the channel is 100d = 0064h.

The calculated CRC is 540Bh.

The request to the device:

SOH	<ver>	<to>	<from>	<len>	STX	<cmd>	<verc>	<channel>	ETX	<cs>	EOT				
1	2	3	4	5	6	7	8	9	10	11	12	13	14	15	16
01h	10h	01h	80h	01h	F0h	04h	02h	23h	10h	64h	00h	03h	0Bh	54h	04h

The response from the device:

SOH	<ver>	<to>	<from>		<len>	STX	<cmd>	<ver>	<status>	<channel>	<typ>	<value>				ETX	<cs>			EO T	
1	2	3	4	5	6	7	8	9	10	11	12	13	14	15	16	17	18	19	20	21	22
01h	10h	01h	80h	01h	F0h	04h	02h	23h	10h	00h	64h	00h	16h	00h	00h	B4h	41h	03h	1Fh	94h	04h

Interpretation of the response:

<status> = 00h device o.k. (≠ 00h signifies error code)
 <typ> = Data type of the following value; 16h = float (4 bytes, IEEE format)
 <value> = 41B40000h corresponds to a float value of 22.5
 The temperature is therefore 22.5°C.

The correct data transmission can be checked with the aid of the check sum (941Fh).

i Little Endian (Intel, low byte first) applies when transmitting word and float variables of addresses or the CRC, for example. This means first the low byte and then the high byte.

8.5.5 Status and Error Codes in Binary Protocol

If a measurement request delivers the <status> 00h, the sensor is working correctly. You can find a complete list of additional codes in the description of the UMB protocol.

Extract from list:

<status>	Description
00h (0d)	Command successful; no error; all o.k.
10h (16d)	Unknown command; not supported by this device
11h (17d)	Invalid parameter
24h (36d)	Invalid channel
28h (40d)	Device not ready; e.g. initialization / calibration running
50h (80d)	Measurement variable (+offset) is outside the set display range
51h (81d)	
52h (82d)	Measurement value (physical) is outside the measuring range (e.g. ADC over range)
53h (83d)	
54h (84d)	Error in measurement data or no valid data available
55h (85d)	Device /sensor unable to carry out valid measurements due to ambient conditions

8.5.6 CRC Calculation

CRC is calculated according to the following rules:

Norm: CRC-CCITT

Polynomial: 1021h = x¹⁶ + x¹² + x⁵ + 1 (LSB first mode)

Start value: FFFFh

You can find further information in the description of a CRC calculation in UMB Protocol.

9 Commissioning for SDI-12 data format

- i The devices can be operated with various protocols, e.g. UMB Binary and UMB-ASCII 2.0. Further information on the protocols and the full description of the UMB channels, or the ASCII, NMEA, SDI-12 and Modbus protocol can be found in the User Manual Ultrasonic Wind Sensors.

9.1 Device set-up

Preconfigured devices with the SDI-12 protocol are available on inquiry.

The communication in SDI-12 mode is conform to the standard defined in "SDI-12 A Serial-Digital Interface Standard for Microprocessor-Based Sensors Version 1.3 January 12, 2009" for all devices. SDI-12 version 1.4 is supported from firmware version v24. The device may be operated in bus mode together with other SDI-12 sensors, connected to one SDI requester (logger).

With firmware version v29, or higher an option for SDI-12 communication over RS485 is available. If this feature is also permitted by the SDI-12 logger in use, it allows communication over longer distances and reduces the susceptibility to electromagnetic interferences compared to the hardware interface defined by the SDI-12 standard.

9.2 Configuration and testing

The parameters for SDI-12 must be set in the ConfigTool.NET software.

- ✓ Hardware version equal or higher 3.0
- ✓ Software version equal or higher 1.5
- ▶ To activate the SDI-12 mode, wire a jumper between the control input and analog ground (pins 3 and 6 of the UMB round connector, or the red and blue wires of the connection cable).
- ▶ Set the *Device Parameters* as follows:
 - Baudrate: 1200 Bd
 - Protocol: SDI-12
 - Parity: 7E1
- ▶ Select the unit *Metric or Imperial (US)* of the transmitted measurement data.
- ▶ Select whether to communicate via the RS485 standard.

- i Using the ISOCON-UMB for SDI-12 over RS485 does not work because the RS485 interfaces of ISOCON-UMB are fixed to 19200 bd.

9.3 Command set

The commands listed below are available for the device. Due to the applied measurement process the device measures continuously in normal operation mode.

This causes the following special properties while in this mode:

- The device does not need a "Wakeup" and does not have a sleep mode. So the reactions to "Break" signals and any related timings are inapplicable. "Break" will be ignored by the devices.
- Data requested with M-commands or C-commands are always available immediately. The device will always respond with a000n resp. a000nn. This means the device will not send any service request and will ignore measurement abort signals. The logger should request the data immediately.
- M-command and C-command only differ in the number of values made available in the buffers (in both cases the maximum permitted by the standards of 9 resp. 20).

- The commands for continuous measurement (R-commands) are used to request the data.

Command	Function
?!	Address search (Wildcard request, one device only on bus!)
a!	Request device active?
aI!	Request device identification
aAb!	Address change to b (0 ... 9, A ... Z, a ... z)
aM!	Measurement basic minimal data set
aM1!	Measurement, Temperature Values
aM2!	Measurement: Wind Values
aM3!	Measurement: Air Pressure Values
aMC!	Measurement, minimal base data set, transmit values with CRC
aMC1! ... aMC3!	Measurement, (value assignment as for aMn! commands), transmission with CRC
aC!	Concurrent measurement, full basic data set
aC1! ... aC3!	Concurrent measurement, (value assignment as for aMn! Commands), extended data set
aCC!	Concurrent measurement, transmit values with CRC
aCC1! ... aCC3!	Concurrent measurement, complete data set,, (value assignment as for aMn! Commands), extended data set , transmit values with CRC
aD0!	Data request buffer 0
aD1!	Data request buffer 1
aD2!	Data request buffer 2
aD3!	Data request buffer 3
aD4!	Data request buffer 4
aR0!	Data request from continuous measurement, data set 0
aR1!	Data request from continuous measurement, data set 1
aR2!	Data request from continuous measurement, data set 2
aR3!	Data request from continuous measurement, data set 3
aR4!	Data request from continuous measurement, data set 4
aRC0!	Data request from continuous measurement, data set 0 with CRC
aRC1!	Data request from continuous measurement, data set 1 with CRC
aRC2!	Data request from continuous measurement, data set 2 with CRC
aRC3!	Data request from continuous measurement, data set 3 with CRC
aRC4!	Data request from continuous measurement, data set 4 with CRC
aV!	Command verification: Evaluate sensor status and heating temperatures, data request with aD0!, aD1!
aXU<m/u>!	Selection of the unit system for SDI-12 data
aXH+nnnn!	Adjust the local altitude for calculation of relative air pressure
aXMn!	Set the heating mode of the device
aXR!	Device reset

Address configuration

The UMB device-ID and SDI-12 address are connected. The different address ranges and the fact that UMB IDs are integer numbers, while SDI-12 addresses are ASCII characters, have to be considered.

The SDI-12 address is built from the UMB device ID as follows: UMB device ID 1 (default) corresponds to SDI-12 address '0' (SDI-12 default).

Changing the SDI-12 address by SDI-12 setting command also modifies the UMB device ID accordingly.

UMB (dec)	SDI-12 (ASCII)
1 to 10	'0' to '9'
18 to 43	'A' to 'Z'
50 to 75	'a' to 'z'

Valid address ranges

9.4 Data messages

To simplify the evaluation, the assignment of measurement values to data buffers '0' ... '9' has been defined uniformly for all measurement commands. The responses to C-requests have been restricted to 35 characters. Buffers '0' to '4' are currently in use. A maximum of 9 values can be transferred; the basic data set of 9 values has been assigned to buffers '0' and '1'.

Buffers '2' to '4', which are available on request by C commands, contain further measurement values. This definition guaranties the compatibility to loggers designed according to older versions of the SDI-12 standard.

The complete range of measurement values, as defined for the UMB protocol, is available in the SDI-12 environment through the additional M and C commands (aM1! ... aM3!, aMC1! ... aMC3!, aC1! ... aC3!, aCC1! ... aCC3!).

If the measurement value is not available, e.g. through sensor failure, this is indicated by a value of +999.0. or -999.9. Using an aV! verification query, the logger evaluates the reason for failure.

- i The configured system of units is not indicated in the data messages. The logger may request this setting with the I-command and adjust the evaluation of the data messages accordingly.
- i The example uses italics to print the requests from the logger (*OM!*).

Example: M Request

OM!

00009<CR><LF>: 9 Values are available

ODO!

0+13.5+2.5+3.7+2.6<CR><LF>

Air temperature 13,5°C, curr.. wind speed 2,5m/s, max. wind speed 3,7m/s, avg.wind speed 2,6m/s

OD1!

0+136.4+134.0+100.0+1010.4+1.160<CR><LF>

Curr. wind direction 136,4 °, avg. wind direction(vct) 134,0 °, quality of wind measurement 100 %, rel. air pressure (curr) 1010.4 hPa, air density 1.16 kg/m³

Example: C Request

OC!

000019<CR><LF>: 18 Values available

OD0!

0+13.5+2.5+3.7+2.6<CR><LF>

Air temperature 13,5°C, curr.. wind speed 2,5m/s, max. wind speed 3,7m/s, avg.wind speed 2,6m/s

OD1!

0+136.4+134.0+100.0+1010.4+1.160<CR><LF>

Curr. wind direction 136,4 °, avg. wind direction(vct) 134,0 °, quality of wind measurement 100 %, rel. air pressure (curr) 1010.4 hPa, air density 1.16 kg/m³

OD2!

0+1.8+2.8+122.0+147.0<CR><LF>

Wind speed (min) 1,8m/s, wind speed (vct)2,8m/s, wind direction (min) 122,0°, wind direction (max) 147,0°

OD3!

0+12.4+14.0+13.5<CR><LF>

Air temperature (min) 12,4°C, air temperature (max) 14,0°C, air temperature (avg) 13,5°C

D4!

0+1008.2+1011.2+1009.1<CR><LF>

Rel. air pressure (min) 1008.2 hPa,rel. air pressure (max) 1011.7 hPa, rel. air pressure (avg) 1009.1 hPa

The table showing the measurement values in the sequence they are arranged in the telegram, can be found in the appendix.

9.5 Additional measurement commands

The following additional measurement commands are available:

- aM1! ... aM3!
- aMC1! ... aMC3! (M-command, data transmission with CRC)
- aC1! ... aC3!
- aCC1! ... aCC3!! (C-command, data transmission with CRC)

The complete data sets of the Ventus, as defined for the UMB protocol are available in a SDI-12 environment as well. The measurement values are ordered according to sensor types. Equally to the base data sets maximum 9 values can be requested with an additional M-command, while an additional C-request allows for up to 20 values. The buffer assignment as documented in the following paragraphs has been structured in a way that with each M-command the buffers D0 and D1 are used. If the respective sensor type has more values available, the buffers D2 up to D4 will be occupied if required.

M1 / C1	Temperature	M: 4 values	C: 4 values
M2 / C2	Wind	M: 9 values	C: 10 values
M3 / C3	Air pressure	M: 8 values	C: 8 values

The table showing the measurement values in the sequence they are arranged in the telegram, can be found in the appendix.

9.6 Message device identification

The device responds to the identification request with following message:

Example: SDI-12 device address '0'

0I!

013Lufft.deVentusy00

y: Metric / US units (m = metric, u = US)

nnn: Software version

Example: Ventus, configured for imperial US units

0I!

013Lufft.deVentusu00

9.7 Message verification



Further information can be found in the User Manual Smart Weather Sensors.

The command verification *aV!* is used to evaluate status information of the device.

The device responds to the request as follows:

a0004<CR<LF>, i.e. 4 values are available in the buffers

The first 2 "measurement values", transmitted in buffer '0' contain the status information of the measurement channels.

Measurement channels	Measurement values
Status group1: +nnnn	Air temperature, air temperature buffer, air pressure, air pressure buffer
Status group1: +nn	Wind, wind buffer

Buffer '0' status informations

The last two values, transmitted in buffer '1', show the heating temperatures of the upper and the lower heating of the wind sensor.

Measurement value	UMB Channel	min	max	Unit
Buffer '1', device configured for metric units				
Heating temp. top	112	-50	+150	°C
Heating temp. bottom	113	-50	+150	°C
Buffer '1', device configured for imperial US units				
Heating temp. top	117	-58	+302	°F
Heating temp. bottom	118	-58	+302	°F

Buffer '1'

The status data of the channels are assembled to form “fake measurement values”, where each digit represents one status. The coding of the status is listed below. Generally each sensor has two status values, one for the current measurement value, and one for the value buffer, which is used for averaging and the evaluation of minimum and maximum.

Sensor status codes:

Sensor status	Code
OK	0
Invalid channel	1
E2_CAL_ERROR E2_CRC_KAL_ERR FLASH_CRC_ERR FLASH_WRITE_ERR FLASH_FLOAT_ERR	2
MEAS_ERROR	3
MEAS_UNABLE	4
INIT_ERROR	5
VALUE_OVERFLOW CHANNEL_OVERRANGE	6
VALUE_UNDERFLOW CHANNEL_UNDERRANGE	7
BUSY	8
Other sensor status	9

Example (SDI-12 Address '0', no error):

```
0V!  
00004<CR><LF>  
0D0!  
0+0000+00<CR><LF>  
0D1!  
0+73.0+65.3<CR><LF>
```

Example (SDI-12 Address '0', temperature sensor failure):

```
0V!  
00004<CR><LF>  
0D0!  
0+0300+00<CR><LF>  
0D1!  
0+73.0+65.3<CR><LF>
```

9.8 Sensor Configuration Commands for Unit System, Altitude, and Heating Mode

Message Selection of Measurement Unit System

The command is used to change the unit system used for the display of the SDI-12 data between metric and US units. The command is implemented as X command.

Command: *aXu<u/m>!*

Response: *aU<u/m><CR><LF>*

u: US-Units, m: Metric Units

Example: Select metric units

0XUm!

0Um<CR><LF>

Message Adjustment of the Altitude

For the calculation of the relative air pressure the local altitude (above sea level) of the device is required.

Command: *aXH+nnnn!*

nnnn: Altitude of Sensor in m

Response: *aXH+nnnn<CR><LF>*

The assignment of an invalid altitude (-100 < altitude < 5000) will be answered with:

aXHf<CR><LF>

Example: Select metric units

0XH+135!

0XH+135<CR><LF>

Message setting of the Heating Mode

The heating of the sensor may be configured in different modes. The SDI12 command sets combinations of heating operation mode and heating power mode.

Command: *aXMn!*

n: Heating Mode (0: Off, 1: Automatic/full power, 2: Automatic/alternating)

Response: *aXMnm<CR><LF>*

n: selected heating mode (0: Off, 1: automatic)

m: selected power mode (0: full, 1: alternating)

The assignment of an invalid heating mode will be answered with

aXMf<CR><LF>

Example: A Ventus shall be set to Automatic/Alternating

0XM2!

0XM11<CR><LF>

10 Commissioning for MODBUS format

i The devices can be operated with various protocols, e.g. UMB Binary and UMB-ASCII 2.0. Further information on the protocols and the full description of the UMB channels, or the ASCII, NMEA, SDI-12 and Modbus protocol can be found in the User Manual Ultrasonic Wind Sensors.

10.1 Device set-up

To enable the integration of Ventus wind meters into PLC and similar environments communication with Modbus protocols is provided.

Measurement values are mapped to Modbus input registers. The range of available values is basically the same as for the UMB protocol, including the translation into different unit systems (metric, imperial ...).

In the interest of safe and simple commissioning we do not use register pairs for floating point or 32 bit integers, as the use of register pairs is not described in the Modbus standard documents. All measurement values are scaled to fit into 16bit integer registers.

10.2 Configuration and testing

The smart weather sensors can be configured for MODBUS-RTU or for MODBUS-ASCII.

The base configuration must be set in the ConfigTool.NET software.

- ▶ Select under *Device parameters* the *Protocol MODBUS-RTU* or *MODBUS-ASCII*.
 - ⇒ The following communication parameters will be preselected: 19200 Bd, even parity.
- ▶ Select the *Baudrate*: 19200, 9600, 4800 or lower.
- ▶ Select the *Interface*: 8E1, 8N1, 8N2.

i The MODBUS communication has been tested for a poll rate of 1 second. The proper function of the device with higher MODBUS poll rates has not been tested.

We suggest to set the poll rate to 10 seconds or slower. The update rate of the data is ≥ 10 seconds, with the exception of the channels "Wind speed / wind direction fast", which are provided for special purposes. For most of the weather data, significant changes have to be expected in the range of minutes.

i If the device has been configured for Modbus communication, analog output functions cannot be used.

10.3 Addressing

The MODBUS address is deducted from the UMB device ID .

A device with UMB device ID 1 also has the UMB address 1.

The valid address range of MODBUS from 1 to 247 is smaller than that of the UMB device IDs. If a UMB device ID > 247 has been selected, the MODBUS address will be set to 247.

10.4 MODBUS functions

For the smart weather sensors, the functions of conformance class 0 and 1 have been implemented, which operate at register level.



Further information can be found in the User Manual Ultrasonic Wind Sensors.

Command	Function	Comment
Conformance Class 0		
0x03	Read holding registers	Selected configuration settings
0x16	Write multiple registers	Selected configuration settings
Conformance Class 1		
0x04	Read input registers	Selected additional operations (from device version 227)
0x06	Write single register	Selected configuration settings
0x07	Read exception status	Currently not used (returns 0)
Diagnostics		
0x11	Report slave ID	(responds also to broadcast address)

10.5 Function 0x03 Read Holding Registers

The Holding Registers are used to make a selected set of adjustable parameters available on Modbus also. Similar to the measurement values are mapped to 16bit integer values, if necessary by appropriate scaling.

Reg. Adr.	Reg. Addr.	Function	Values	Scale
1	0	Local Altitude	Altitude in m, for calculation of relative air pressure Value range -100 ... 5000	1.0
2	1	Heating operating mode	High-Byte: Heating Operating Mode ¹ Low-Byte Heating Power Mode ²	
3	2	Stationsreset	(function when writing only, returns always 0)	

¹ Value Range High-Byte (Operating Mode):

0	Off
1	Automatic
2	Test Mode (maintenance only)
3	Off, if ext. control line „high“, otherwise automatic
4	Off, if ext. control line „low“, otherwise automatic

² Value range Low-Byte (Power Mode):

0	Full heating power
1	Reduced heating power, alternating lower and upper heating element

The register value is calculated as (power mode) + 256 * (operating mode),
 e.g. full power, automatic: 0 + 256 * 1 = 256, or reduced power, automatic: 1 + 256 * 1 = 257

10.6 Function 0x06 Write Holding Register, 0x10 Write Multiple Registers

Selected parameters of the Ventus can be adjusted by writing to the Modbus holding registers. Register assignment refer to the previous chapter. The values are checked for plausibility. Improper values will not be accepted and cause a Modbus exception. Writing the value 0x3247 (12871d) into register no. 3 (register adr. 2) will trigger a device reset.

10.7 Function 0x04 read input registers

The input registers are containing the measurement values of the device and the related status information.

The measurement values are mapped to the 16 bit registers using the following scaling factors:

- 0 ... 65530 for unsigned values
- -32762 ... 32762 for signed values

The values 65535 (0xffff) and 32767 are used for the indication of erroneous or not available measurement values. A more detailed specification of the error can be evaluated from the status registers.

The assignment of the values to the register addresses (0 ... 124) has been arranged in a way so that the most frequently used data can be read out with just a few register block requests.

The following blocks have been defined:

- Status information
- Frequently used values which are independent of the unit system (metric / imperial) in use.
- Frequently used values in metric units
- Frequently used values in imperial units
- Other measurement values

When using the metric unit system the first three blocks can supply all data required with one request. There is no difference in the register assignment between the product variants. If, dependent on the variant, some value is not available, this will be indicated by setting the register to the error value.

i The following tables mainly show average values.

Register number	Register address	Value (UMB channel)	Range	Scaling, signed/unsigned, remarks
Status information				
1	0	Identification	High Byte: Device Subtype LowByte: Software Version	
2	1	Device Status	Device status unequal 0 indicates a serious problem when reading the configuration storage or	

Register number	Register address	Value (UMB channel)	Range	Scaling, signed/unsigned, remarks
			during system start. Please contact Lufft Service with reference to the indicated code.	
3	2	Sensor Status 1	Air temperature buffer, air temperature, air pressure buffer, air pressure (High byte -> low byte, see table below)	Coding 4 bit per status, s. below
4	3	Sensor Status 2	Windbuffer, wind (high byte, see table below)	Coding 4 bit per status, s. below
5	4	Reserved		
6	5	Reserved		
7	6	Reserved		
8	7	Reserved		
9	8	Reserved		
10	9	-	Diagnostic: run time in 10 seconds steps	

Register number	Register address	Value (UMB channel)	Range	Scaling factor signed/unsigned
		Values Independent of the Unit System		
11	10	305	Rel. Air Pressure (act.)	Factor 10, s
12	11	325	Rel. Air Pressure (min.)	Factor 10, s
13	12	345	Rel. Air Pressure (max.)	Factor 10, s
14	13	365	Rel. Air Pressure (avg.)	Factor 10, s
15	14	500	Wind Direction (act.)	Factor 10, s
16	15	520	Wind Direction (min.)	Factor 10, s
17	16	540	Wind Direction (max.)	Factor 10, s
18	17	580	Wind Direction (vct.)	Factor 10, s
19	18	805	Wind Measurement Quality	Factor 1, s
		Values in Metric Units		
20	19	100	Air Temperature °C (act.)	Factor 10, s
21	20	120	Air Temperature °C (min.)	Factor 10, s
22	21	140	Air Temperature °C (max.)	Factor 10, s
23	22	160	Air Temperature °C (avg.)	Factor 10, s
24	23	112	Heating Temperature top °C	Factor 10, s
25	24	113	Heating Temperature bottom °C	Factor 10, s
26	25	400	Wind Speed m/s (act.)	Factor 10, s
27	26	420	Wind Speed m/s (min.)	Factor 10, s
28	27	440	Wind Speed m/s (max.)	Factor 10, s
29	28	460	Wind Speed m/s (avg.)	Factor 10, s

Register number	Register address	Value (UMB channel)	Range	Scaling factor signed/unsigned
30	29	480	Wind Speed m/s (vct.)	Factor 1, s
		Values in imperial US Units		
31	30	105	Air Temperature °F (act.)	Factor 10, s
32	31	125	Air Temperature °F (min.)	Factor 10, s
33	32	145	Air Temperature °F (max.)	Factor 10, s
34	33	165	Air Temperature °F (avg.)	Factor 10, s
35	34	117	Heating Temperature top °F	Factor 10, s
36	35	118	Heating Temperature bottom °F	Factor 10, s
37	36	410	Wind Speed mph (act.)	Factor 10, s
38	37	430	Wind Speed mph (min.)	Factor 10, s
39	38	450	Wind Speed mph (max.)	Factor 10, s
40	39	470	Wind Speed mph (avg.)	Factor 10, s
41	40	490	Wind Speed mph (vct.)	Factor 10, s
		Additional Measurement Values		
42	41	300	Abs. Air Pressure (act.)	Factor 10, s
43	42	320	Abs. Air Pressure (min.)	Factor 10, s
44	43	340	Abs. Air Pressure (max.)	Factor 10, s
45	44	360	Abs. Air Pressure (avg.)	Factor 10, s
46	45	405	Wind Speed km/h (act.)	Factor 10, s
47	46	425	Wind Speed km/h (min.)	Factor 10, s
48	47	445	Wind Speed km/h (max.)	Factor 10, s
49	48	465	Wind Speed km/h (avg.)	Factor 10, s
50	49	485	Wind Speed km/h (vct.)	Factor 10, s
51	50	415	Wind Speed kts (act.)	Factor 10, s
52	51	435	Wind Speed kts (min.)	Factor 10, s
53	52	455	Wind Speed kts (max.)	Factor 10, s
54	53	475	Wind Speed kts (avg.)	Factor 10, s
55	54	495	Wind Speed kts (vct.)	Factor 10, s
56	55	310	Air Density kg/m ³ (act.)	Factor 1000, u
57	56	443	Wind Gust Speed m/s	Factor 10, s
58	57	543	Wind Gust Direction	Factor 10, s
59	58	448	Wind Gust Speed km/h	Factor 10, s
60	59	453	Wind Gust Speed mph	Factor 10, s
61	60	503	Wind Gust Speed kts	Factor 10, s
	...	Reserve		
125	124			

10.8 Sensor status

Each register holds 4 sensor states, coded with 4 bits per state, which together form a 16-bit number. The sequence is defined from the most significant half-byte to the least significant half-byte. Most sensors have 2 status values, one for the sensor and the current measurement value, another one for the buffer, from which the average value and the minimum and maximum values are evaluated.

Assignment of Status Information to Status Register:

Register	Byte	Half-Byte	Status
Sensor Status 1	High	High	Temperature buffer
		Low	Temperature
	Low	High	Air pressure buffer
		Low	Air pressure
Sensor Status 2	High	High	Wind buffer
		Low	Wind
	Low	High	0
		Low	0

Example Sensor Status 1:

Temperature buffer status, temperature status, air pressure buffer status, air pressure status

High Byte		Low Byte	
High	Low	High	Low
Temperature buffer	Temperature	Air pressure buffer	Air pressure
5	3	0	7

The example values above (for illustration only, the given combination will not occur in reality) are combined to the register value $0x5307 = 21255$.

The single status are retrieved from the register as integer part of

Status 1 = register / 4096

Status 2 = (register / 256) AND 0x000F

Status 3 = (register / 16) AND 0x000F

Status 4 = register AND 0x000F

Following table shows the status coding:

Sensor state	Code
OK	0
UNGLTG_KANAL	1
E2_CAL_ERROR E2_CRC_KAL_ERR FLASH_CRC_ERR FLASH_WRITE_ERR FLASH_FLOAT_ERR	2

Sensor state	Code
MEAS_ERROR MEAS_UNABLE	3
INIT_ERROR	4
VALUE_OVERFLOW CHANNEL_OVERRANGE VALUE_UNDERFLOW CHANNEL_UNDERRANGE	5
BUSY	6
Other Sensor State	7

Coding of sensor status

11 Maintenance

11.1 Maintenance schedule

The frequency of cleaning is dependent upon the local weather and environmental conditions.

The following maintenance intervals are recommended:

Interval	Activity	Performed by
Annually	<ul style="list-style-type: none">▶ Check the device for cleanliness.▶ Check the device by carrying out a measurement request.	Operator

11.2 Updating firmware

The firmware can be updated with the ConfigTool.NET software. The firmware is valid for all types of the device. The description of the update can be found in the ConfigTool.NET software.

- ▶ Download the latest version of the firmware and the ConfigTool.NET software: www.lufft.com/resources/.
- ▶ Install the update on a Windows® PC.

i During firmware update the interface must be set to half-duplex operation settings.

12 Troubleshooting

12.1 Error elimination

Error	Possible cause	Corrective action
Device does not allow polling or does not respond	Device does not work properly	<ul style="list-style-type: none"> ▶ Check the power supply. ▶ Check the interface connection.
Device does not allow polling or does not respond	Incorrect device ID is applied	▶ Check if the correct device ID is assigned. Devices are delivered with ID 1.
Wind direction values are incorrect	Device is not aligned correctly	▶ Check that the device is aligned to the north.
Device transmits error value 28h (40d)	Device is in the initialization phase following startup	▶ Wait for approx. 10 seconds. The device delivers measurements after approx. 10 seconds.
Device transmits error value 50h (80d)	Device is being operated above the limit of the specified measuring range	–
Device transmits error value 51h (81d)	Device is being operated below the limit of the specified measuring range	–
Device transmits error value 55h (85d) during wind measurement	Device is being operated well above the limit of the specified measuring range	–
Device transmits error value 55h (85d) during wind measurement	Very strong horizontal rain or snow	–
Device transmits error value 55h (85d) during wind measurement	There are foreign objects within the measuring section of the wind meter	–
Device transmits error value 55h (85d) during wind measurement	Wind meter sensors are very dirty	▶ Clean the sensor.
Device transmits error value 55h (85d) during wind measurement	Wind meter sensors are iced over	▶ Check the heating mode in the configuration and check the heating function / connection.
Device transmits error value 55h (85d) during wind measurement	One of the wind meter's sensors is faulty	▶ Return the device to the manufacturer for repair.
Quality of the wind measurement is not always 100 %	In normal operation the device should always transmit 90 – 100 %. Values up to 50 % do not represent a general problem. When the error value 55h (85d) is transmitted, this value is 0 %. If the device permanently transmits values below 50 %, this may mean that there is a fault.	–

Error	Possible cause	Corrective action
Device transmits an unknown error value	–	▶ Report any malfunction to the representative of OTT HydroMet.
Minimum value of wind direction greater than maximum value	Minimum and maximum value of wind direction indicates the direction at which the minimum and maximum wind speed was measured.	–

13 Repair

13.1 Customer support

- ▶ Have repairs carried out by OTT HydroMet service personnel.
- ▶ Only carry out repairs yourself, if you have first consulted OTT HydroMet.
- ▶ Contact your local representative: www.otthydromet.com/en/contact-us
- ▶ Include the following information:
 - instrument model
 - instrument serial number
 - details of the fault or problem
 - examples of data files
 - readout device or data acquisition system
 - interfaces and power supplies
 - history of any previous repairs or modifications
 - pictures of the installation
 - overview of the local environment conditions

14 Notes on disposing of old devices

Member States of the European Union

In accordance with the German Electrical and Electronic Equipment Act (ElektroG; national implementation of EU Directive 2012/19/EU), OTT HydroMet takes back old devices in the Member States of the European Union and disposes of them in the proper manner. The devices that this concerns are labeled with the following symbol:



- ▶ For further information on the take-back procedure contact OTT HydroMet:

OTT HydroMet Fellbach GmbH

Service & Technical Support

Gutenbergstraße 20

70736 Fellbach

Germany

phone: +49 711 518 22 0

email: met-support@otthydromet.com

All other countries

- ▶ Dispose of the product in the proper manner following decommissioning.
- ▶ Observe the country-specific regulations on disposing of electronic equipment.
- ▶ Do NOT dispose of the product in household waste.

15 Technical data

15.1 General technical data

Specification	Value
Fastening	Pole with diameter 50 mm
Housing	Seawater-resistant aluminum AlMg3Si
Protection class	III (SELV)
Protection type	IP68 (metal) IP66 (plastics)
Operating temperature range (with heating)	-40 to +60 °C
Operating temperature range (without heating)	-20 to +60 °C
Humidity range	0 to 100 %
Storage temperature range	-55 to +80 °C
Humidity range (non-condensing, during storage)	0 to 95 %

15.2 Electrical data

Weather sensor

Specification	Value
Power supply	24 V DC \pm 10 %
Power supply with reduced heating power (25 %)	12 DC \pm 10 %

Variant	Current consumption	Power input	Heating
Ventus UMB V200A UMB	ca. 77 mA	1.2 VA at 24 V DC	-
Ventus UMB	max. 10 A	230 VA at 24 V DC	x
Ventus X UMB	max. 10 A	240 VA at 24 V DC	x
V200A UMB	max. 1000 mA	21.6 VA at 24 V DC	x

15.3 Data transfer

Specification	Value
Interfaces/ protocols	RS485 half- or full-duplex, two- or four-wire (UMB, SDI-12, NMEA or MODBUS protocol) or analog interface
Data bits	8 (UMB) 7 (SDI-12)
Stop bit	1
Parity	No (UMB) Even (SDI-12)

Specification	Value
Tri-state	2 bits after stop bit edge
Baudrate	19200 (UMB) 1200 (SDI-12)
Adjustable baud rates	1200, 2400, 4800, 9600, 14400, 19200, 28800, 57600
Analog interface circuits (2 adjustable channels)	A: 0 or 4 – 20 mA / 0 or 2 – 10 V / 2 – 2000 Hz B: 0 or 4 – 20 mA / 0 or 2 – 10 V
Maximum load	300 Ohm
Resolution	16 bits
Channels	Adjustable
Update rate	250 ms; 1 sec to 10 sec

15.4 Dimensions and weight

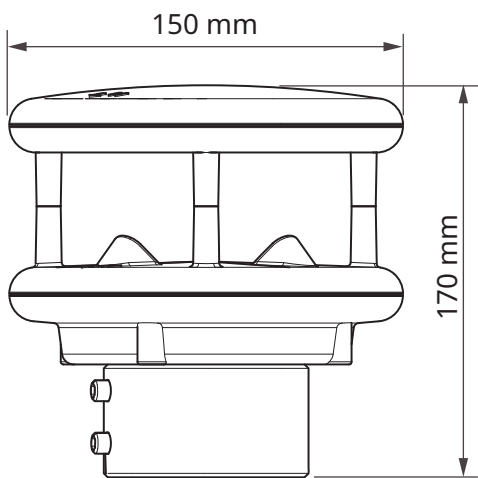

Ventus or Ventus-X (including mounting bracket), approx. 1620 g

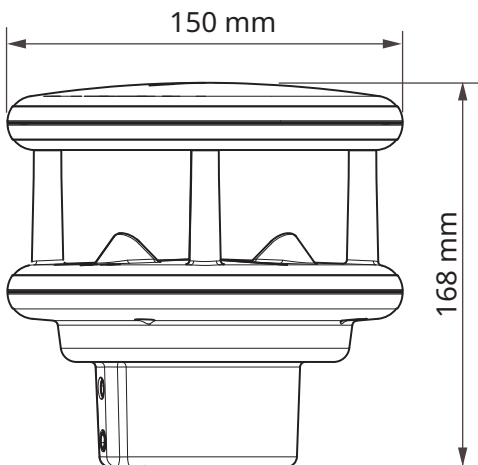

V200A (including mounting bracket), approx. 800 g

15.5 Measuring range and accuracy

Wind speed

Specification	Value
Measurement process	Ultrasound
Measuring range	0 to 90 m/s
Resolution	0.01 m/s
Accuracy	± 0.2 m/s or ± 2 % (0 to 65 m/s) RMS (metal) (the higher value) ± 5 % (> 65 m/s) RMS (metal) ± 0.3 m/s or ± 3 % (0 to 35 m/s) RMS (plastics) (the higher value) ± 5 % (> 35 m/s) RMS (plastics)
Response threshold	0.1 m/s (metal) 0.3 m/s (plastics) Adjustable, starting from 0.01 m/s
Sampling rate	250 ms; 1 sec to 10 sec
Internal sampling rate	60 Hz
Units	m/s; km/h; mph; kts

Wind direction

Specification	Value
Measurement process	Ultrasonic
Measuring range	0 to 359.9°
Resolution	0.1°
Accuracy	< 2° (> 1 m/s) RMSE (metal) < 3° (> 1 m/s) RMSE (plastics)
Response threshold	0.1 m/s (metal) 0.3 m/s (plastics) Adjustable, starting from 0.01 m/s
Sampling rate	250 ms; 1 sec to 10 sec
Internal sampling rate	60 Hz

Virtual temperature

Specification	Value
Measurement process	Ultrasound
Measuring range	-50 °C to +70 °C
Resolution	0.1 °C
Accuracy	± 2.0 K (unheated and without solar irradiation or wind speed above 4 m/s)
Sampling rate	1 sec to 10 sec
Units	°C; °F

Air pressure

Specification	Value
Measurement process	MEMS sensor - capacitive
Measuring range	300 to 1200 hPa
Resolution	0.1 hPa
Accuracy	±1.5 hPa
Sampling rate	10 sec
Unit	hPa

16 Appendix

16.1 Channel list summary

The channel assignment described here applies to online data requests in binary and ASCII protocol.

UMB Channel							Measuring Range		
act	min	max	avg	special	Measurement Variable (float)	min	max	unit	
Temperature									
100	120	140	160	–	Virtual temperature	-50.0	70.0	°C	
105	125	145	165	–	Virtual temperature	-58.0	158.0	°F	
112	–	–	–	–	Heating temperature top	-50.0	150.0	°C	
113	–	–	–	–	Heating temperature bottom	-50.0	150.0	°C	
117	–	–	–	–	Heating temperature top	-58.0	302.0	°F	
118	–	–	–	–	Heating temperature bottom	-58.0	302.0	°F	
Air pressure									
300	320	340	360	–	Absolute air pressure	300.0	1200.0	hPa	
305	325	345	365	–	Relative air pressure	300.0	1200.0	hPa	
310	–	–	–	–	Air density	0.0	3.0	kg/m ³	
Wind									
				vect. avg					
400	420	440	460	480	Wind speed	0	90.0	m/s	
405	425	445	465	485	Wind speed	0	324.0	km/h	
410	430	450	470	490	Wind speed	0	201.3	mph	
415	435	455	475	495	Wind speed	0	174.8	kts	
443	–	–	–	–	wind gust speed	0	90.0	m/s	
448	–	–	–	–	wind gust speed	0	324.0	km/h	
453	–	–	–	–	wind gust speed	0	201.3	mph	
458	–	–	–	–	wind gust speed	0	174.8	kts	
500	520	540	–	580	wind direction	0	359.0	°	
543	–	–	–	–	wind gust direction	0	359.0	°	
805	–	–	–	–	wind value quality	0	100	%	
Status information									
4006					Status supply voltage, upper threshold (~ 28V)	0 : Voltage <= 28V 1: Voltage > 28V			
4007					Status supply voltage, lower threshold (~ 20V)	0 : Voltage >= 20V 1: Voltage < 20V			
4997					Status lower heating	0: Heating off 1: Heating on			
4998					Status lower heating	0: Heating off 1: Heating on			

Information about the channel list summary according to TLS2002 can be found in the User Manual Ultrasonic Wind Sensors.

16.2 Buffer assignment measurement data

Measurement value	UMB channel	Minimum	Maximum	Unit
Buffer '0' in metric units				
Air temperature (act)	100	-50.0	70.0	°C
Wind speed (act)	400	0	90	m/s
Wind speed (max)	440	0	90	m/s
Wind Speed (avg)	460	0	90	m/s
Buffer '0' in imperial US units				
Air temperature (act)	105	-58.0	158	°F
Wind speed (act)	410	0	201.3	mph
Wind speed (max)	450	0	201.3	mph
Wind Speed (avg)	470	0	201.3	mph
Buffer '1' in metric units				
Wind Direction (act)	500	0.0	359.9	°
Wind Direction (vct)	580	0.0	359.9	°
Wind Quality	805	0.0	100.0	%
Rel. Air Pressure (act)	305	300.0	1200.0	hPa
Air Density (act)	310	0.000	3.000	kg/m ³
Buffer '1' in imperial US units				
Wind Direction (act)	500	0.0	359.9	°
Wind Direction (vct)	580	0.0	359.9	°
Wind Quality	805	0.0	100.0	%
Rel. Air Pressure (act)	305	300.0	1200.0	hPa
Air Density (act)	310	0.000	3.000	kg/m ³
Buffer '2' in metric units				
Wind Speed (min)	420	0.0	90.0	m/s
Wind Speed (vct)	480	0.0	90.0	m/s
Wind Direction (min)	520	0.0	359.9	°
Wind Direction (max)	540	0.0	359.9	°
Buffer '2' in imperial US units				
Wind Speed (min)	430	0.0	201.3	mph
Wind Speed (vct)	490	0.0	201.3	mph
Wind Direction (min)	520	0.0	359.9	°
Wind Direction (max)	540	0.0	359.9	°
Buffer '3' in metric units				
Air temperature (min)	120	-50.0	70.0	°C
Air temperature (max)	140	-50.0	70.0	°C
Air temperature (avg)	160	-50.0	70.0	°C

Measurement value	UMB channel	Minimum	Maximum	Unit
Buffer '3' in imperial US units				
Air temperature (min)	125	-58.0	158.0	°F
Air temperature (max)	145	-58.0	158.0	°F
Air temperature (avg)	165	-58.0	158.0	°F
Buffer '4' in metric units				
Rel. Air Pressure (min)	325	300.0	1200.0	hPa
Rel. Air Pressure (max)	345	300.0	1200.0	hPa
Rel. Air Pressure (avg)	365	300.0	1200.0	hPa
Buffer '4' in imperial US units				
Rel. Air Pressure (min)	325	300.0	1200.0	hPa
Rel. Air Pressure (max)	345	300.0	1200.0	hPa
Rel. Air Pressure (avg)	365	300.0	1200.0	hPa

16.3 Buffer assignment additional measurement data

Buffer Assignment Additional Measurement Data M1 / C1 Temperature

Measurement value	UMB Channel	Minimum	Maximum	Unit
Buffer '0' in metric units				
Air temperature (act)	100	-50.0	70.0	°C
Air temperature (min)	120	-50.0	70.0	°C
Air temperature (max)	140	-50.0	70.0	°C
Air temperature (avg)	160	-50.0	70.0	°C
Buffer '0' in imperial US units				
Air temperature (act)	105	-58.0	158.0	°F
Air temperature (min)	125	-58.0	158.0	°F
Air temperature (max)	145	-58.0	158.0	°F
Air temperature (avg)	165	-58.0	158.0	°F

Buffer Assignment Additional Measurement Data M2 / C2 Wind

Measurement value	UMB Channel	Minimum	Maximum	Unit
Buffer '0' in metric units				
Wind Speed (act)	400	0.0	90.0	m/s
Wind Speed (min)	420	0.0	90.0	m/s
Wind Speed (max)	440	0.0	90.0	m/s
Wind Speed (avg)	460	0.0	90.0	m/s
Wind Speed (vct)	480	0.0	90.0	m/s
Buffer '0' in imperial US units				
Wind Speed (act)	410	0.0	201.3	mph
Wind Speed (min)	430	0.0	201.3	mph

Measurement value	UMB Channel	Minimum	Maximum	Unit
Wind Speed (max)	450	0.0	201.3	mph
Wind Speed (avg)	470	0.0	201.3	mph
Wind Speed (vct)	490	0.0	201.3	mph
Buffer '1' in metric units				
Wind Direction (act)	500	0.0	359.9	°
Wind Direction (min)	520	0.0	359.9	°
Wind Direction (max)	540	0.0	359.9	°
Wind Direction (vct)	580	0.0	359.9	°
Buffer '1' in imperial US units				
Wind Direction (act)	500	0.0	359.9	°
Wind Direction (min)	520	0.0	359.9	°
Wind Direction (max)	540	0.0	359.9	°
Wind Direction (vct)	580	0.0	359.9	°
Buffer '2' in metric units				
Wind Measurement Quality	805	0.0	100.0	%
Wind Gust Speed	443	0.0	90.0	m/s
Wind Gust Direction	543	0.0	359.9	°
Buffer '2' in imperial US units				
Wind Measurement Quality	805	0.0	100.0	%
Wind Gust Speed	453	0.0	201.3	mph
Wind Gust Direction	543	0.0	359.9	°

Buffer Assignment Additional Measurement Data M3 / C3 Air Pressure

Measurement value	UMB channel	Minimum	Maximum	Unit
Buffer '0' in metric or imperial US units:				
Abs. Air Pressure (act)	300	300.0	1200.0	hPa
Abs. Air Pressure (min)	320	300.0	1200.0	hPa
Abs. Air Pressure (max)	340	300.0	1200.0	hPa
Abs. Air Pressure (avg)	360	300.0	1200.0	hPa
Buffer '1' in metric or imperial US units:				
Rel. Air Pressure (act)	305	300.0	1200.0	hPa
Rel. Air Pressure (min)	325	300.0	1200.0	hPa
Rel. Air Pressure (max)	345	300.0	1200.0	hPa
Rel. Air Pressure (avg)	365	300.0	1200.0	hPa
Buffer '2' in metric or imperial US units:				
Air Density (act)	310	0.000	3.000	kg/m ³



Contact Information

